

Fire detection and alarm systems for buildings

Part 3. Specification for automatic release mechanisms for certain fire protection equipment



* 5 *

ICS 13.220.20; 13.320

NO COPYING WITHOUT BSI PERMISSION EXCEPT AS PERMITTED BY COPYRIGHT LAW



Foreword

This Part of BS 5839 has been prepared under the direction of the Fire Standards Committee. It is based on proposals submitted by the British Fire Protection Systems Association Ltd.

Fire protection equipment such as fire doors, fire shutters and fire dampers are required to be closed in the event of fire, but it may be inconvenient to have them closed at all other times. Accordingly they may be held open and, in the event of fire, released by one of the automatic release mechanisms specified in this standard. A fire alarm system, a fire detection and alarm system or one or more fire detectors may provide the signal for the operation of an automatic release mechanism. A central control may be necessary to ensure that all fire protection equipment can be released in the absence of people in the building.

Although automatic release mechanisms complying with this Part of BS 5839 are intended for the release to a closed state of fire doors, etc., which are normally held open, they may also be suitable for the release, to an open state, of fire protection equipment such as covers to openings for smoke control. However, compliance with this Part of BS 5839 should not be taken as implying their suitability for such uses.

Most fire doors and other fire protection equipment that can be held by one of the automatic release mechanisms specified herein may be released without a significant safety hazard requiring additional precautions or, in the event of release in the absence of fire, significant cost or inconvenience. A code of practice for control of the automatic operation of fixed fire extinguishers, fire extinguishing systems and other fire protection measures is in preparation. That code of practice may be relevant if the release of the fire door or other fire protection

equipment would require additional safety precautions or if release in the absence of a fire would be costly or inconvenient.

Additional requirements, such as the appropriate requirements of BS 5345, may have to be met for automatic release mechanisms intended for use where there may be an explosive or flammable atmosphere.

NOTE. Attention is drawn to BS EN 1155 which specifies the requirements and test methods for 24 V d.c. electrically powered hold-open devices for swing doors.

The tests are type tests and are not intended as manufacturers' tests to maintain uniformity of quality in production, which is dealt with in BS 5750. While the tests are intended to assess the most important features of the design and construction of automatic release mechanisms, they cannot remove the necessity for regular inspection and maintenance, which is essential for reliable operation.

Product certification. Users of this Part of BS 5839 are advised to consider the desirability of third party certification of product conformity with this British Standard based on testing and continuing surveillance, which may be coupled with assessment of a supplier's quality systems against the appropriate Part of BS 5750.

Enquiries as to the availability of third party certification schemes will be forwarded by BSI to the Association of Certification Bodies. If a third party certification scheme does not already exist, users should consider approaching an appropriate body from the list of Association members.

Compliance with a British Standard does not itself confer immunity from legal obligations. In particular, attention is drawn to the fact that the use of an automatic release mechanism may not be permitted in all circumstances by a fire or statutory authority or may only be permitted subject to further conditions. Fire insurers may also place restrictions on the use of automatic release mechanisms.

Summary of pages

The following table identifies the current issue of each page. Issue 1 indicates that a page has been introduced for the first time by amendment. Subsequent issue numbers indicate an updated page.

Page	Issue	Page	Issue
Front cover	2	1 to 12	original
Inside front cover	2	13	2
a	1	Back cover	2
b	blank		



S

Contents

	Page
Foreword	Inside front cover
Committees responsible	Back cover
Specification	
Section one. General	
1 Scope	2
2 Definitions	2
Section two. Requirements	
3 Construction requirements	3
4 Electrical requirements	3
5 Performance requirements	3
6 Marking and data	4
Section three. Tests	
7 Testing	5
8 Damp heat (steady state) and insulation resistance	5
9 Temperate conditions	6
10 Cold	6
11 SO ₂ corrosion	7
12 Durability	7
13 Impact	11
14 Vibration	11
15 Pressure test for fluidic pressure controlled mechanisms	12
Appendix	
A Operation test	13
Tables	
1 Schedule of tests	5
2 Holding forces	11
Figure	
1 Durability and operation test apparatus	8

BS 5839 : Part 3 : 1988
Specification. Section one

Section one. General

1 Scope

This Part of BS 5839 specifies construction, electrical and performance requirements and methods of test for automatic release mechanisms for certain fire protection equipment. The automatic release mechanisms are intended to hold open (or closed) fire protection equipment such as fire doors, fire shutters, fire dampers, etc. against the force of a door-closing (or door-opening) mechanism, and to release the fire door, fire shutter, fire damper, etc. on manual operation or on receipt of a signal from a fire detection system, one or more smoke or fire detectors or from a central point in a building.

This standard does not cover the following:

- (a) devices for the release of automatic extinguishing systems or fixed fire extinguishers;
 - (b) fusible links and thermal trips used for releasing fire doors, fire shutters, fire dampers, etc. which are not part of a fire detection and alarm system and which therefore do not affect the design and construction of any fire detection and alarm system that may be installed;
 - (c) closing (or opening) mechanisms, e.g. door closers;
- NOTE 1. Door closers are specified in BS 6459.
- (d) release mechanisms incorporated into closing or opening mechanisms;
 - (e) release mechanisms which utilize friction between the mechanism and a fixed surface to prevent the door closing, e.g. plunger type devices;
 - (f) fire detection and alarm systems and smoke or fire detectors nor their disposition;
 - (g) precautions that may be necessary if the release of fire protection equipment is either hazardous or, in the absence of any fire, costly or inconvenient;
 - (h) apparatus that may send a signal to release.

NOTE 2. In this standard, to avoid repetition, the term 'open' includes the term 'closed' and conversely, and the term 'door' includes fire doors, fire shutters, fire dampers and other fire protection equipment that are required to be held against the force of a door-closing (or door-opening) device and released when necessary.

NOTE 3. The titles of the publications referred to in this Part of BS 5839 are listed on the inside back cover.

2 Definitions

For the purposes of this Part of BS 5839 the following definitions apply.

2.1 automatic release mechanism. A device that may be used for holding a door in the open position, against the action of a door closer, and automatically releasing under specified conditions.

NOTE. Such devices usually consist of two separate components, one attached to the door and the other to the building structure.

2.2 door closer. A mechanism attached to a door that will automatically close the door provided that the closing force is not overcome by an automatic release mechanism or obstacle.

NOTE. Building regulations may describe such a mechanism as a self-closing mechanism.

2.3 electromagnetic automatic release mechanism. A device that converts electrical energy into a magnetic force that acts directly as the holding force.

2.4 electromechanical automatic release mechanism. A mechanical holding device that is operated by electrical energy.

2.5 fluidic pressure controlled automatic release mechanism. A mechanism that holds and releases because of pressure or a change in pressure in a fluid.

2.6 holding force. The force required to release the door when the automatic release mechanism is energized.

2.7 residual holding force. The force required to release the door when the automatic release mechanism is de-energized.

Section two. Requirements

3 Construction requirements

3.1 General requirements

3.1.1 The automatic release mechanism shall have means for mounting which shall be accessible without disassembling any part of the mechanism.

NOTE. Removal of a complete assembly is not considered to be disassembling the mechanism.

3.1.2 Removal of a protective cover shall not be possible without the use of a tool.

3.1.3 Enclosures for moving or electrically live parts shall be protected against the ingress of foreign bodies and moisture to a minimum classification of IP41 when tested in accordance with BS 5490.

3.2 Requirements for fluidic pressure controlled automatic release mechanisms

3.2.1 It shall not be possible to release the pipe connection to the automatic release mechanism without the use of a tool either on the connection itself or on any cover over the connection.

3.2.2 Flexible pressure lines subject to movement during the operation of the device shall be protected from chaffing, stress and fatigue.

3.2.3 The fluidic operating medium shall be inert, non-flammable and non-toxic.

3.2.4 The automatic release mechanism and its associated hydraulic system shall comply with BS 4575 : Part 1.

4 Electrical requirements

4.1 Leads connected to parts on any hinged or removable cover shall be of sufficient length and flexibility to permit access.

4.2 Sufficient space shall be provided within any terminal enclosure to allow conductors to be easily introduced and any cover fitted, without risk of the conductors or their insulation being damaged, or the operation of moving parts being impaired.

4.3 The three test specimens (see 7.1) of electromagnetic and electromechanical automatic release mechanisms shall comply with the following clauses and subclauses of BS 3955 : 1986, taking into consideration any movement of parts of the automatic release mechanism:

(a) **7.1.3.1** concerning precautions for installation;

- (b) **7.1.3.2** concerning marking of controls that have to be earthed;
- (c) **7.1.3.3** concerning a label on flexible cables or cords;
- (d) clause **8** concerning protection against electric shock;
- (e) clause **9** concerning provision for earthing;
- (f) clause **10** concerning terminals;
- (g) clause **11** concerning construction;
- (h) clause **13** concerning insulation resistance and electric strength;
- (i) clause **20** concerning creepage distances, clearances and distances through insulation;
- (j) clause **21** concerning resistance to heat, fire and tracking.

5 Performance requirements

5.1 Environmental conditions

The automatic release mechanism shall be capable of performing all its functions in the environmental conditions expected in buildings; the automatic release mechanism shall be deemed to satisfy this requirement if, when subjected to the tests described in clauses **8**, **9**, **10** and **11**, it satisfies the criteria for compliance specified in **8.3.1**, **8.3.4**, **8.3.5**, **9.3.1**, **9.3.3**, **10.3** and **11.3**.

5.2 Surface and component temperatures

The external surface of the automatic release mechanism shall remain relatively cool in use. Parts of the mechanism accessible by removing any cover(s), but without dismantling the mechanism, shall not become excessively hot in use. The automatic release mechanism is deemed to satisfy these requirements if, when subjected to the tests described in clauses **8** and **9**, it satisfies the criteria for compliance specified in **8.3.2**, **8.3.3** and **9.3.2**.

5.3 Quality of construction

The automatic release mechanism shall be robustly constructed to ensure that the mechanism will not be damaged in normal use; the automatic release mechanism shall be deemed to satisfy this requirement if, when subjected to the tests described in clauses **12**, **13**, **14** and, for fluidic pressure controlled mechanisms only, clause **15**, it satisfies the criteria for compliance specified in those clauses.

BS 5839 : Part 3 : 1988
Section two

6 Marking and data

6.1 The following information shall be marked on the automatic release mechanism in such a position that it is conspicuous during maintenance:

- (a) the number and date of this Part of BS 5839, i.e. BS 5839 : Part 3 : 1988*;
- (b) the name or trademark of the manufacturer or supplier;
- (c) the type or model number;
- (d) one of the following as appropriate:
 - (1) for electrically operated automatic release mechanisms intended for use with mains voltages, the nominal value or range(s) of the supply voltage and frequency, the nominal current consumption (in amperes), and terminal markings;
 - (2) for electrically operated automatic release mechanisms not intended for use with mains voltages, the maximum and minimum supply voltages, the nominal current consumption (in amperes), and terminal markings;
 - (3) for fluidic pressure controlled automatic release mechanisms, the operating fluid, the nominal value and operating range of the supply pressure, and a warning to indicate components under pressure;
- (e) the rated holding force.

6.2 The information specified in **6.1** shall comply with the legibility and durability requirements specified in appendix B of BS 3955 : 1986.

6.3 The manufacturer/supplier's approved installation procedure shall be provided, either marked on the automatic release mechanism or in the form of instructions supplied with the automatic release mechanism.

6.4 Instructions shall be supplied with an automatic release mechanism and shall include the following:

- (a) the maximum and residual holding forces;
- (b) a warning against installation in any way that would make warping of a door more likely, such as the following:

'This automatic release mechanism should be applied to a door in such a position that the door is not permanently warped and unable to seal satisfactorily in the closed position. If the door is not strong enough to resist permanent warping, the automatic release mechanism and the door closing mechanism should act on a line at right angles to a line through the hinges.'
- (c) the operating signal for hold and for release;
- (d) one of the following, as appropriate:
 - (1) for electrically operated automatic release mechanisms, the maximum and minimum sizes of cables to be used to connect to terminals or any connector or plug and socket used on the automatic release mechanism;
 - (2) for fluidic power controlled automatic release mechanisms, details of the supply tubing;
- (e) the maximum misalignment with which the automatic release mechanism is to be installed;
- (f) any requirement for the marking of the cable (see items (b) and (c) of **4.3**);
- (g) fixing instructions, which may include or consist of a template;
- (h) where release of the mechanism can be prevented by mechanical damage, or damage by fire, to the supply circuit, a recommendation for the protection of the supply circuit, referring to clause **17** of BS 5839 : Part 1 : 1988 for electrical circuits and to clause **7** of BS 4575 : Part 1 : 1979 for fluidic circuits.

*Marking BS 5839 : Part 3 : 1988 on or in relation to a product represents a manufacturer's declaration of conformity, i.e. a claim by or on behalf of the manufacturer that the product meets the requirements of the standard. The accuracy of the claim is therefore solely the responsibility of the person making the claim. Such a declaration is not to be confused with third party certification of conformity, which may also be desirable.

Section three. Tests

7 Testing

NOTE. These tests are type tests, and the existence of a satisfactory test certificate cannot of itself be taken as an indication of compliance with this Part of BS 5839 of products subsequently produced, as this will depend on the manufacturer's quality systems. It may be necessary for some or all of the tests to be repeated whenever materials or the manufacturing process are modified, dependent on an evaluation of the effect of the alterations on the validity of the original test certificate. This evaluation should be carried out either by the issuer of the test certificate or by another equally competent body.

7.1 Test specimens

Three specimens shall be provided for use in the tests described in clauses 8 to 15. The test specimens shall be representative of the product being tested. The three test specimens shall be arbitrarily numbered 1, 2 and 3. Any decorative facia or surround supplied by the manufacturer shall be in place during testing.

7.2 Test schedule

The tests on each specimen indicated in table 1 shall be carried out in the order in which they are listed.

Test	Clause	Specimen number		
		1	2	3
Damp heat (steady state) and insulation resistance	8		X	X
Temperate conditions	9		X	X
Cold	10		X	X
SO ₂ corrosion	11	X	X	
Durability	12	X	X	X
Impact	13	X		X
Vibration	14	X		
Pressure test*	15	X	X	X

*For fluidic pressure controlled mechanisms only.

7.3 Supply voltages

7.3.1 Nominal supply voltage. If not marked on the test specimen, the nominal supply voltage shall be taken to be the mean of the minimum and maximum supply voltages. Where more than one nominal supply voltage is marked on a test specimen the same nominal supply voltage shall be used for all the tests listed in table 1.

7.3.2 Minimum and maximum supply voltages.

The minimum supply voltage shall be taken to be either the minimum voltage marked on the test specimen or 85 % of the nominal supply voltage, whichever is the lower. The maximum supply voltage shall be taken to be either the maximum voltage marked on the test specimen or 110 % of the nominal supply voltage, whichever is the greater. Where the nominal supply voltage is expressed as a range, e.g. 220 V a.c. to 240 V a.c., the minimum supply

voltage shall be taken to be 85 % of the minimum nominal supply voltage, and the maximum supply voltage shall be taken to be 110 % of the maximum nominal supply voltage.

7.4 Standard atmospheric conditions for testing

Unless particular values are specified in a method of test, measurements and visual observations before, during and after each test shall be carried out in the standard atmospheric conditions for testing described in BS 2011 : Part 1.1, i.e.:

- (a) temperature: 15 °C to 35 °C;
- (b) relative humidity: 45 % to 75 %;
- (c) barometric pressure: 86 kPa to 106 kPa.

The temperature and humidity shall be substantially constant for each test where the standard atmospheric conditions are applied.

7.5 Tolerances

If a specific tolerance or limit is not specified in a method of test a tolerance of ± 5 % shall be applied.

8 Damp heat (steady state) and insulation resistance

8.1 Object of the test

To determine the suitability of the mechanism to withstand and operate under conditions of high relative humidity, where the absorption of humidity is mainly by diffusion.

A test of the insulation resistance is included to ensure that an acceptable level of insulation resistance can be maintained after being subjected to humid conditions.

8.2 Test procedure

8.2.1 General. Carry out the test procedure described in BS 2011 : Part 2.1Ca, applying the conditioning severities given in 8.2.3.

8.2.2 State of the specimen during conditioning.

Mount the test specimen on the apparatus described in A.1. Connect the test specimen to the maximum supply voltage (see 7.3.2) or maximum operating pressure (see item (d) of 6.1) as appropriate. With the test specimen in its normally energized condition, apply a force equal to the rated holding force (see item (e) of 6.1).

8.2.3 Conditioning. Apply the following severity of conditioning:

- (a) temperature: 40 ± 2 °C;
- (b) relative humidity: 93⁺²₋₃ %;
- (c) duration: 16 h;
- (d) recovery period 12 h.

8.2.4 Measurements during conditioning. Record whether the test specimen releases during the conditioning. At the end of the conditioning period, whilst maintaining the severity of conditioning, record the temperature of all parts accessible after the removal of any covers, but without dismantling the specimen, and record the highest temperature of the exterior surface of the test specimen.

BS 5839 : Part 3 : 1988

Section three

8.2.5 Final measurements. After the recovery period, subject the test specimen to the operation test described in appendix A. Within 1 h of the operation test, disconnect the specimen and perform the following.

- (a) Cover double insulated equipment with conductive foil and treat an electrical connection to the foil as the earth terminal.
- (b) Mount the specimen on a metal plate and connect the metal plate to the earth terminal(s) of the specimen.
- (c) Apply a test voltage between the metal plate and the terminals for external conductors (excluding earth terminals) connected together. The test voltage shall be direct current and shall be equal to the highest of 50 V, twice the maximum voltage of the specimen, and 220 % of the nominal voltage of the specimen. After the voltage has been applied for 60 ± 5 s, record the insulation resistance between the metal plate and the connected together terminals.

8.3 Criteria for compliance

- 8.3.1** The test specimen shall not release during the conditioning.
- 8.3.2** The temperatures recorded for parts accessible after the removal of any cover(s) shall not exceed the relevant temperatures in table 13 of BS 3955 : 1986.
- 8.3.3** The highest exterior surface temperature recorded shall not exceed 70°C .
- 8.3.4** The test specimen shall not release when subjected to a force less than the rated holding force (see **A.2.2**).
- 8.3.5** The test specimen shall release when subjected to a force greater than the maximum holding force (see **A.2.3**).
- 8.3.6** The time to release for the operation test (see **A.2.5**) shall not exceed 4.0 s.
- 8.3.7** The insulation resistance recorded shall not be less than $9\text{ M}\Omega$.

9 Temperate conditions**9.1 Object of the test**

To verify the performance of the mechanism and to ensure that exposed surfaces of the mechanism do not become dangerously hot.

9.2 Test procedure

- 9.2.1** Mount the test specimen on the apparatus described in **A.1**. Connect the test specimen to the maximum supply voltage (see **7.3.2**) or maximum operating pressure (see item (d) of **6.1**) as appropriate.
- 9.2.2** Apply a force equal to the rated holding force (see item (e) of **6.1**).
- 9.2.3** Maintain the ambient temperature at $20 \pm 5^{\circ}\text{C}$ for 20 h, recording whether the test specimen releases during this period.
- 9.2.4** At the end of the conditioning period (see **9.2.3**), and whilst maintaining the ambient temperature at

$20 \pm 5^{\circ}\text{C}$, record the highest temperature measured on the exterior surface of the test specimen.

9.2.5 Subject the test specimen to the operation test described in appendix A.

9.3 Criteria for compliance

- 9.3.1** The test specimen shall not release during conditioning (see **9.2.3**).
- 9.3.2** The highest exterior surface temperature recorded shall not exceed 45°C .
- 9.3.3** The test specimen shall not release when subjected to a force less than the rated holding force (see **A.2.2**).
- 9.3.4** The test specimen shall release when subjected to a force greater than the maximum holding force (see **A.2.3**).
- 9.3.5** The time to release for the operation test (see **A.2.5**) shall not exceed 4.0 s.

10 Cold**10.1 Object of the test**

To determine the suitability of the mechanism to operate under conditions of low ambient temperature.

10.2 Test procedure

- 10.2.1 General.** Carry out the test procedure as described in test Ad of BS 2011 : Part 2.1A.
- 10.2.2 State of the specimen during conditioning.** Mount the test specimen on the apparatus described in **A.1**. Connect the test specimen to the minimum supply voltage (see **7.3.2**) or minimum operating pressure (see item (d) of **6.1**) as appropriate. With the test specimen in its normally energized condition apply a force equal to the rated holding force (see item (e) of **6.1**).
- 10.2.3 Conditioning.** Apply the following severity of conditioning:
 - (a) temperature: $-10 \pm 2^{\circ}\text{C}$;
 - (b) duration: 16 h.
- 10.2.4 Measurements during conditioning.** Record whether the test specimen releases during the conditioning.
- 10.2.5 Final measurements.** Subject the test specimen to the operation test described in appendix A.

10.3 Criteria for compliance

- 10.3.1** The test specimen shall not release during the conditioning.
- 10.3.2** The test specimen shall not release when subjected to a force less than the rated holding force (see **A.2.2**).
- 10.3.3** The test specimen shall release when subjected to a force greater than the maximum holding force (see **A.2.3**).
- 10.3.4** The time to release for the operation test (see **A.2.5**) shall not exceed 4.0 s.

11 SO₂ corrosion

11.1 Object of the test

To determine the suitability of the mechanism for use and storage in an atmosphere combining high relative humidity and a high sulphur dioxide content.

11.2 Test procedure

11.2.1 General. Carry out the test procedure described in BS 2011 : Part 2.1Kc, applying the conditioning severity given in 11.2.3.

11.2.2 State of the specimen during conditioning.

Connect not less than 115 mm of 1.38 mm diameter single core copper cable (untinned) or 115 mm of the tubing specified in item (d) (2) of 6.3 to the normal terminal connection on each test specimen.

NOTE. If the terminals will not accept 1.38 mm diameter cable, then use cable of the diameter nearest to 1.38 mm which can be accepted.

Connect test specimen no. 2 to the nominal supply voltage (see 7.3.1) or nominal operating pressure (see item (d) of 6.1).

11.2.3 Conditioning. Apply the following severity of conditioning:

- (a) temperature: 25 ± 2 °C
- (b) relative humidity: 93^{+2}_{-3} %;
- (c) SO₂ corrosion: 25 ± 5 p.p.m. (V/V);
- (d) exposure period: 21 days;
- (e) recovery period: 7 days.

11.2.4 Final measurements. Subject test specimen no. 2 to the operation test described in appendix A, taking care not to disturb the connections between the test specimen and the cable or tubing.

11.3 Criteria for compliance

11.3.1 The test specimen shall not release when subjected to a force less than the rated holding force (see A.2.2).

11.3.2 The test specimen shall release when subjected to a force greater than the maximum holding force (see A.2.3).

11.3.3 The time to release for the operation test (see A.2.5) shall not exceed 4.0 s.

12 Durability

12.1 Object of the test

To determine the suitability of the mechanism to withstand the repeated slamming together of the two parts of the mechanism.

12.2 Apparatus

The apparatus shall consist of the following:

- (a) means for rigidly mounting the part of the test specimen (see part A in figure 1) normally attached to the structure of the building in its recommended operating position;

- (b) means for causing the part of the test specimen (see part B in figure 1) normally attached to a door to strike part A (see figure 1) using a mass which acts under gravitational acceleration, via a link wire, and which accelerates from rest through a distance of 180 mm. The link wire shall comply with BS 302 : Part 2, shall have a diameter of 6 mm and shall be of 6 × 19 (12/6/1) construction with a fibre main core. The pulley shall have a diameter of not less than 72 mm and shall be mounted on low friction bearings;

- (c) 7.5 kg and 15 kg masses.

A suitable apparatus is shown in figure 1.

12.3 Test procedure

12.3.1 Mount the test specimen such that, upon impact, the angle between the two impact faces will be the maximum permitted in the instructions (see item (e) of 6.4).

12.3.2 Using the mass of 15 kg in the apparatus described in 12.2, cause part B (see figure 1) to strike part A (see figure 1) by operating the trigger mechanism.

12.3.3 Using the mass of 7.5 kg in the apparatus described in 12.2, cause part B (see figure 1) to strike part A (see figure 1) 500 times.

12.3.4 Record whether the test specimen satisfies the criterion for classification as IP4X in accordance with BS 5490.

12.3.5 Record whether it is possible to remove any protective cover without the use of a tool and, for fluidic pressure controlled mechanisms only, whether it is possible to release the pipe connection to the test specimen without the use of a tool either on the connection itself or on any cover over the connection.

12.3.6 Subject the test specimen to the operation test described in appendix A.

12.4 Criteria for compliance

12.4.1 The test specimen shall be classified as IP4X in accordance with BS 5490.

12.4.2 Removal of a protective cover shall not be possible without the use of a tool, nor shall it be possible to release the pipe connection to a fluidic pressure controlled test specimen without the use of a tool either on the pipe connection or on any cover to the connection.

12.4.3 The test specimen shall not release when subjected to a force less than the rated holding force (see A.2.2).

12.4.4 The test specimen shall release when subjected to a force greater than the maximum holding force (see A.2.3).

12.4.5 The time to release for the operation test (see A.2.5) shall not exceed 4.0 s.

BS 5839 : Part 3 : 1988
Section three

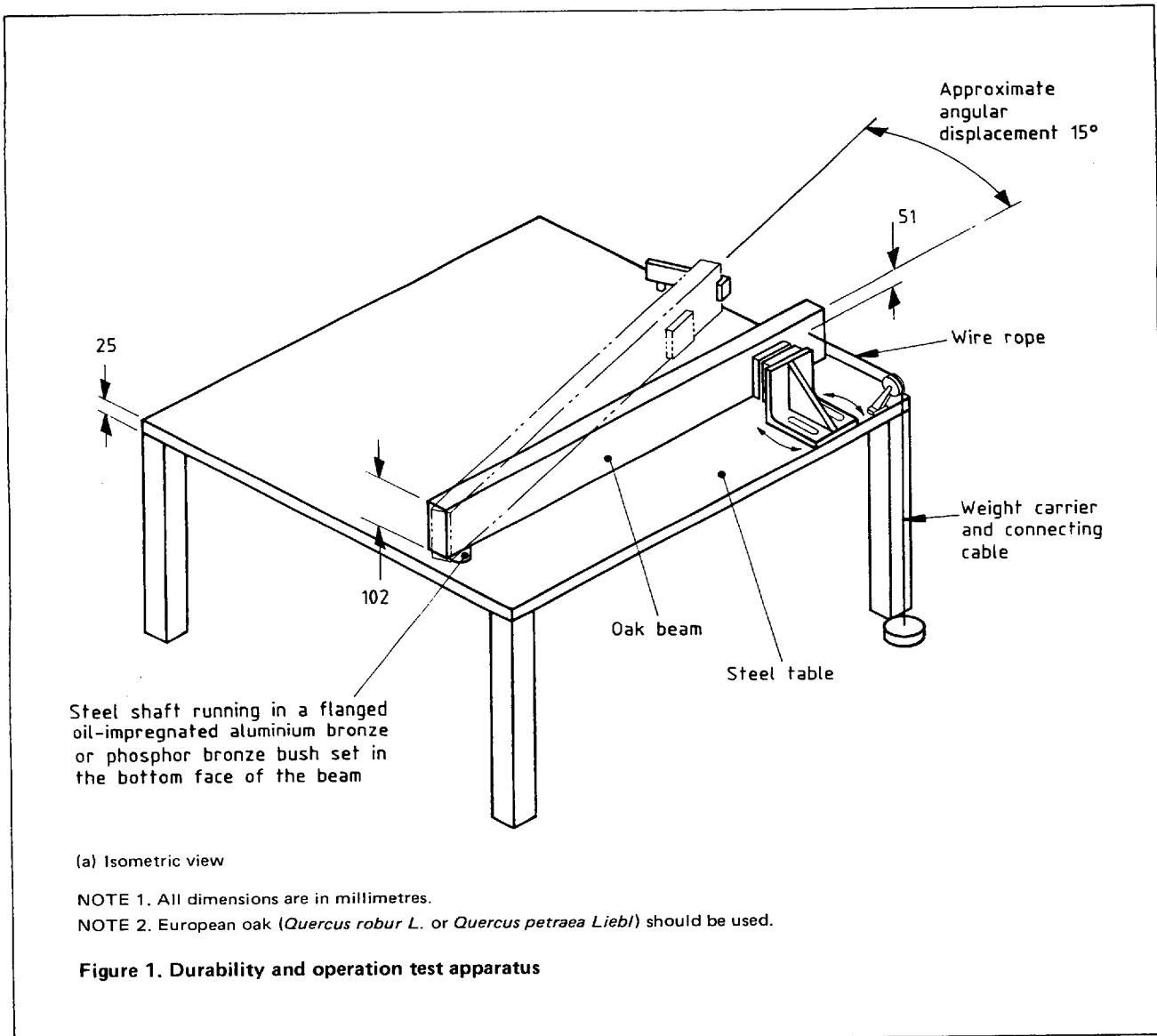

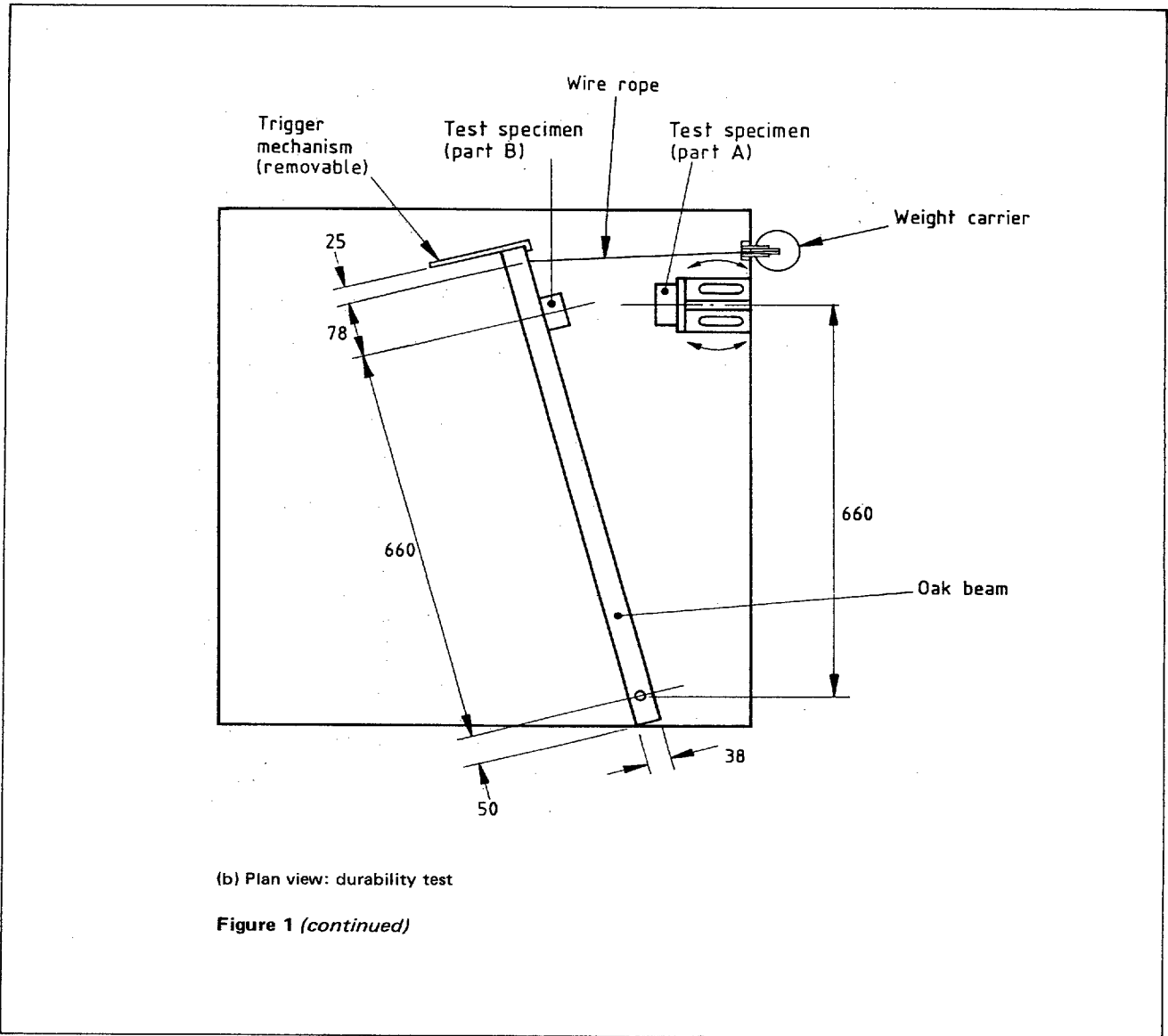

(b) Plan view: durability test

Figure 1 (continued)

BS 5839 : Part 3 : 1988
Section three

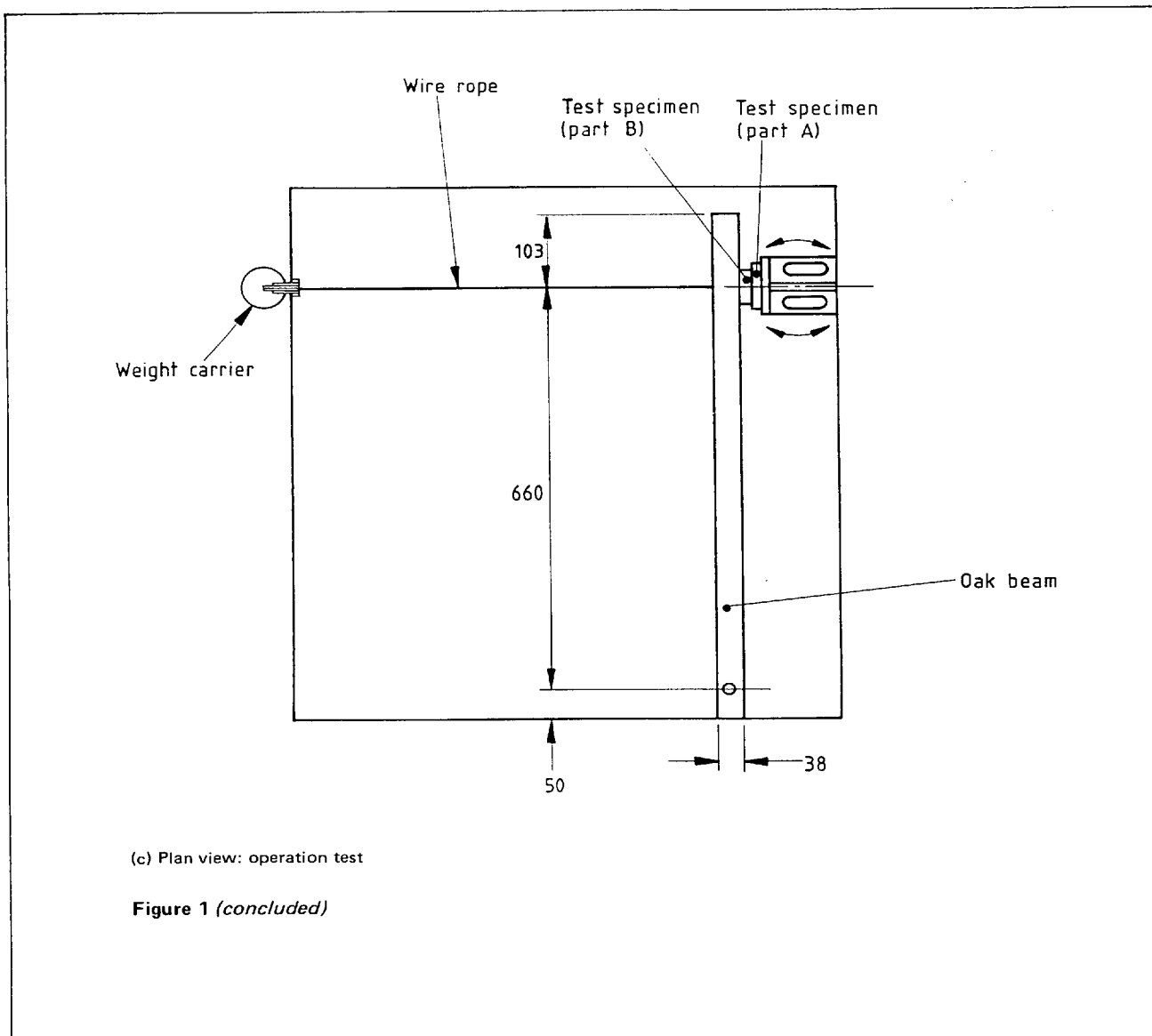

13 Impact

13.1 Object of the test

To ensure that mechanical impacts to the exposed surfaces of the mechanism will neither impair the operation of the mechanism nor release any protective covers.

13.2 Apparatus

Spring-operated impact-test apparatus which is in accordance with 18.2.1 of BS 3955 : 1986, and which shall produce a blow with energy at the moment of impact of 0.5 ± 0.04 N·m.

13.3 Test procedure

13.3.1 Mount the test specimen as described in A.2. Connect the test specimen to the nominal supply voltage (see 7.3.1) or nominal operating pressure (see item (d) of 6.1) as appropriate.

13.3.2 Apply the appropriate maximum residual holding force (see table 2).

13.3.3 Apply 20 impacts to the test specimen, distributed arbitrarily over its exposed surfaces.

13.3.4 Record whether the test specimen satisfies the criterion for classification as IP4X in accordance with BS 5490.

13.3.5 Record whether it is possible to remove any protective cover without the use of a tool and, for fluidic pressure controlled mechanisms only, whether it is possible to release the pipe connection to the test specimen without the use of a tool either on the connection itself or on any cover over the connection.

13.3.6 Visually inspect the test specimen for internal mechanical damage.

13.3.7 Subject the specimen to the operation test described in appendix A.

Rated holding force	Maximum residual holding force
N	N
Less than 111	5
111 to 310	10
311 to 580	30
More than 580	45

13.4 Criteria for compliance

13.4.1 The test specimen shall be classified as IP4X in accordance with BS 5490.

13.4.2 Removal of a protective cover shall not be possible without the use of a tool, nor shall it be possible to release the pipe connection to a fluidic pressure controlled test specimen without the use of a tool either on the connection or on any cover to the connection.

13.4.3 The impact blows shall not have caused any visible internal mechanical damage.

13.4.4 The test specimen shall not release when subjected to a force less than the rated holding force (see A.2.2).

13.4.5 The test specimen shall release when subjected to a force greater than the maximum holding force (see A.2.3).

13.4.6 The time to release for the operation test (see A.2.5) shall not exceed 4.0 s.

14 Vibration

14.1 Object of the test

To determine the ability of the mechanism to withstand prolonged exposure to vibration transmitted through its mountings.

14.2 Test procedure

14.2.1 General. Carry out the test procedure described in BS 2011 : Part 2.1Fc, applying the conditioning severity given in 14.2.3.

Expose the test specimen to the conditioning vibration in each of three mutually perpendicular planes in turn, one of which is perpendicular to the plane of mounting of the test specimen.

14.2.2 State of the specimen during conditioning. Mount the test specimen in accordance with BS 2011 : Section 4.1.

14.2.3 Conditioning. Apply the following severity of conditioning:

- (a) frequency range: 10 Hz to 150 Hz;
- (b) acceleration amplitude: $29.43 \text{ m}\cdot\text{s}^{-2}$;
- (c) number of axes: 3;
- (d) number of sweep cycles* per axis: 20.

14.2.4 Final measurements. Record whether the test specimen satisfies the criterion for classification as IP4X in accordance with BS 5490.

Record whether it is possible to remove any protective cover without the use of a tool and, for fluidic pressure controlled mechanisms only, whether it is possible to release the pipe connection to the test specimen without the use of a tool either on the connection itself or on any cover over the connection.

Visually inspect the test specimen for mechanical damage, both externally and internally.

Subject the test specimen to the operation test described in appendix A.

14.3 Criteria for compliance

14.3.1 The test specimen shall be classified as IP4X in accordance with BS 5490.

14.3.2 Removal of a protective cover shall not be possible without the use of a tool, nor shall it be possible to release the pipe connection to a fluidic pressure controlled test

*The sweep cycle consists of a traverse of the specified frequency range once in each direction, i.e. 10 Hz to 150 Hz to 10 Hz. The sweeping is continuous and the frequency changes exponentially with time with a sweep rate of 1 ± 0.1 octaves/minute.

specimen without the use of a tool either on the connection or on any cover to the connection.

14.3.3 The vibration shall not have caused any mechanical damage.

14.3.4 The test specimen shall not release when subjected to a force less than the rated holding force (see **A.2.2**).

14.3.5 The test specimen shall release when subjected to a force greater than the maximum holding force (see **A.2.3**).

14.3.6 The time to release for the operation test (see **A.2.5**) shall not exceed 4.0 s.

15 Pressure test for fluidic pressure controlled mechanisms

15.1 Object of the test

To ensure that the mechanism will withstand the pressures it will meet in use.

15.2 Test procedure

15.2.1 Raise the pressure of the supply source to 1.5 times the maximum operating pressure (see item (d) of **6.1**), and maintain the pressure for 20 h at an ambient temperature of 20 ± 3 °C.

15.2.2 Release the pressure for 30 min, then raise it to 1.5 times the maximum permissible supply pressure, and maintain the pressure for 2 h at an ambient temperature of 20 ± 3 °C.

15.2.3 Bubble or stain test the device and record any visible leaks.

15.2.4 Release the pressure for 30 min and then raise it to the maximum operating pressure for 30 min.

15.2.5 Bubble or stain test the device and record any visible leaks.

15.3 Criterion for compliance

The pressure test shall not cause any visible leaks.

Appendix

Appendix A. Operation test

A.1 Apparatus

The apparatus shall consist of the following:

- (a) a means of mounting the test specimen in its recommended operating position; and
- (b) a means of applying a force to the test specimen in the opposite direction to that applied by the test specimen.

NOTE. The apparatus required for the durability test will be suitable if provided with a second weight carrier (see figure 1(c)).

A.2 Test procedure

A.2.1 Mount the test specimen on the apparatus described in A.1. Connect the test specimen to the minimum supply voltage (see 7.3.2) or minimum operating pressure (see item (d) of 6.1) as appropriate.

A.2.2 Allow the test specimen to remain in the quiescent no-load condition for at least 60 min. Apply a force of 1 N less than the rated holding force and report whether the test specimen releases.

A.2.3 Remove the force, increase the supply voltage or operating pressure to the maximum specified in 7.3.2 or item (d) of 6.1 as appropriate, and allow the test specimen to remain in the quiescent no-load condition for at least 60 min. Apply a force of 1 N more than the maximum holding force (see 6.4 (a)) and record whether the test specimen releases.

A.2.4 Connect the test specimen to the nominal supply voltage (see 7.3.1) or nominal operating pressure (see item (d) of 6.1) as appropriate.

A.2.5 Apply the appropriate maximum residual holding force (see table 2) for 4 h. Disconnect the power supply (or release the supply pressure) and record whether the test specimen releases within 4.0 s.



S

Publications referred to

BS 302	Stranded steel wire ropes Part 2 Specification for ropes for general purposes
BS 2011	Basic environmental testing procedures Part 1.1 General and guidance Part 2.1A. Test A. Cold Part 2.1Ca. Test Ca. Damp heat, steady state Part 2.1Fc. Test Fc. Vibration (sinusoidal) Part 2.1Kc. Test Kc. Sulphur dioxide test for contacts and connections Section 4.1 Specification for mounting of components, equipment and other articles for dynamic tests
BS 3955	Specification for electrical controls for household and similar general purposes
BS 4575	Fluid power transmission and control systems Part 1 Guide for hydraulic equipment and systems
*BS 5345	Code of practice for the selection, installation, and maintenance of electrical apparatus for use in potentially explosive atmospheres (other than mining applications or explosive processing and manufacture)
BS 5490	Specification for classification of degrees of protection provided by enclosures
*BS 5750	Quality systems
BS 5839	Fire detection and alarm systems for buildings Part 1 Code of practice for system design, installation and servicing
BS 6459	Door closers
*BS EN 1155	Building hardware — Electrically powered hold-open devices for swing doors — Requirements and test methods

*Referred to in the foreword only.

This British Standard, having been prepared under the direction of the Fire Standards Committee, was published under the authority of the Board of BSI and comes into effect on 29 April 1988.

© British Standards Institution, 1998

ISBN 0 580 15787 3

The following BSI references relate to the work on this standard: Committee reference FSM/12 Draft for comment 82/11073 DC.

BSI is the independent national body responsible for preparing British Standards. It presents the UK review on standards in Europe and at the international level. It is incorporated by Royal Charter.

Revisions

British Standards are updated by amendment or revision. Users of British Standards should make sure that they possess the latest amendments or editions.

It is the constant aim of BSI to improve the quality of our products and services. We would be grateful if anyone finding an inaccuracy or ambiguity while using this British Standard would inform the Secretary of the responsible technical committee, the identity of which can be found on the inside front cover. Tel: 0181 996 9000; Fax: 0181 996 7400.

BSI offers members an individual updating service called PLUS which ensures that subscribers automatically receive the latest editions of standards.

Buying standards

Orders for all BSI, international and foreign standards publications should be addressed to Customer Services. Tel: 0181 996 7000; Fax: 0181 996 7001.

In response to orders for international standards, it is BSI policy to supply the BSI implementation of those that have been published as British Standards, unless otherwise requested.

Information on standards

BSI provides a wide range of information on national, European and international standards through its Library and its Technical Help to Exporters Service. Contact the Information Centre. Tel: 0181 996 7111; Fax: 0181 996 7048.

Subscribing members of BSI are kept up to date with standards developments and receive substantial discounts on the purchase price of standards. For details of these and other benefits contact Membership Administration. Tel: 0181 996 7002; Fax: 0181 996 7001.

Copyright

Copyright subsists in all BSI publications. BSI also holds the copyright, in the UK, of the publications of the international standardization bodies. Except as permitted under the Copyright, Designs and Patents Act 1988 no extract may be reproduced, stored in a retrieval system or transmitted in any form or by any means – electronic, photocopying, recording or otherwise – without prior written permission from BSI.

This does not preclude the free use, in the course of implementing the standard, of necessary details such as symbols, and size, type or grade designations. If these details are to be used for any other purpose than implementation then the prior written permission of BSI must be obtained.

If permission is granted, the terms may include royalty payments or a licensing agreement. Details and advice can be obtained from the Copyright Manager. Tel: 0181 996 7070.

Committees responsible for this British Standard

The preparation of this British Standard was entrusted by the Fire Standards Committee (FSM/-) to Technical Committee FSM/12, upon which the following bodies were represented:

- British Fire Protection Systems Association Ltd.
- British Telecommunications plc
- Chartered Institution of Building Services Engineers
- Chief and Assistant Chief Fire Officers' Association
- Department of Health and Social Security
- Department of the Environment (Building Research Establishment (Fire Research Station))
- Department of the Environment (Property Services Agency)
- Department of Transport (Marine Directorate)

- Electrical Contractors' Association
- Electrical Installation Equipment Manufacturers' Association (BEAMA Ltd.)
- Fire Insurers' Research and Testing Organisation (FIRTO)
- Fire Offices Committee
- Fire Protection Association
- Home Office
- Institution of Electrical Engineers
- Institution of Fire Engineers
- Ministry of Defence
- National Inspection Council for Electrical Installation Contracting
- Royal Institute of British Architects
- Society of Fire Protection Engineers
- Trades Union Congress

Amendments issued since publication

Amd. No.	Date	Text affected
10207	November 1998	Insertion of note in foreword <i>SH 20-10-98</i>

British Standards Institution · 389 Chiswick High Road London W4 4AL · Telephone 0181 996 9000 · Fax 0181 996 7400

**Amendment No. 1**

**published and effective from 15 November 1998
to BS 5839 : Part 3 : 1988**

Fire detection and alarm systems for buildings**Part 3. Specification for automatic release mechanisms for certain fire protection equipment****Instructions for replacement of pages**

The following pages contain new or revised text. Please remove any superseded pages and insert the new or revised pages in the position given in the summary of pages (see page a). Where only one of the two pages on each sheet has been updated, the other page has been reprinted.

Front cover and inside front cover

a

13

Back cover

You may wish to retain the superseded pages, e.g. for reference purposes. If so please mark them "Superseded by issue X", where "X" is the appropriate issue number. If you do not wish to retain the superseded pages, please destroy them.



S

Fire detection and alarm systems for buildings

Part 3. Specification for automatic release mechanisms for certain fire protection equipment



ICS 13.220.20; 13.320

NO COPYING WITHOUT BSI PERMISSION EXCEPT AS PERMITTED BY COPYRIGHT LAW



Foreword

This Part of BS 5839 has been prepared under the direction of the Fire Standards Committee. It is based on proposals submitted by the British Fire Protection Systems Association Ltd.

Fire protection equipment such as fire doors, fire shutters and fire dampers are required to be closed in the event of fire, but it may be inconvenient to have them closed at all other times. Accordingly they may be held open and, in the event of fire, released by one of the automatic release mechanisms specified in this standard. A fire alarm system, a fire detection and alarm system or one or more fire detectors may provide the signal for the operation of an automatic release mechanism. A central control may be necessary to ensure that all fire protection equipment can be released in the absence of people in the building.

Although automatic release mechanisms complying with this Part of BS 5839 are intended for the release to a closed state of fire doors, etc., which are normally held open, they may also be suitable for the release, to an open state, of fire protection equipment such as covers to openings for smoke control. However, compliance with this Part of BS 5839 should not be taken as implying their suitability for such uses.

Most fire doors and other fire protection equipment that can be held by one of the automatic release mechanisms specified herein may be released without a significant safety hazard requiring additional precautions or, in the event of release in the absence of fire, significant cost or inconvenience. A code of practice for control of the automatic operation of fixed fire extinguishers, fire extinguishing systems and other fire protection measures is in preparation. That code of practice may be relevant if the release of the fire door or other fire protection

equipment would require additional safety precautions or if release in the absence of a fire would be costly or inconvenient.

Additional requirements, such as the appropriate requirements of BS 5345, may have to be met for automatic release mechanisms intended for use where there may be an explosive or flammable atmosphere.

NOTE. Attention is drawn to BS EN 1155 which specifies the requirements and test methods for 24 V d.c. electrically powered hold-open devices for swing doors.

The tests are type tests and are not intended as manufacturers' tests to maintain uniformity of quality in production, which is dealt with in BS 5750. While the tests are intended to assess the most important features of the design and construction of automatic release mechanisms, they cannot remove the necessity for regular inspection and maintenance, which is essential for reliable operation.

Product certification. Users of this Part of BS 5839 are advised to consider the desirability of third party certification of product conformity with this British Standard based on testing and continuing surveillance, which may be coupled with assessment of a supplier's quality systems against the appropriate Part of BS 5750.

Enquiries as to the availability of third party certification schemes will be forwarded by BSI to the Association of Certification Bodies. If a third party certification scheme does not already exist, users should consider approaching an appropriate body from the list of Association members.

Compliance with a British Standard does not itself confer immunity from legal obligations. In particular, attention is drawn to the fact that the use of an automatic release mechanism may not be permitted in all circumstances by a fire or statutory authority or may only be permitted subject to further conditions. Fire insurers may also place restrictions on the use of automatic release mechanisms.

Summary of pages

The following table identifies the current issue of each page. Issue 1 indicates that a page has been introduced for the first time by amendment. Subsequent issue numbers indicate an updated page.

Page	Issue	Page	Issue
Front cover	2	1 to 12	original
Inside front cover	2	13	2
a	1	Back cover	2
b	blank		



S

Appendix

Appendix A. Operation test

A.1 Apparatus

The apparatus shall consist of the following:

- (a) a means of mounting the test specimen in its recommended operating position; and
- (b) a means of applying a force to the test specimen in the opposite direction to that applied by the test specimen.

NOTE. The apparatus required for the durability test will be suitable if provided with a second weight carrier (see figure 1 (c)).

A.2 Test procedure

A.2.1 Mount the test specimen on the apparatus described in A.1. Connect the test specimen to the minimum supply voltage (see 7.3.2) or minimum operating pressure (see item (d) of 6.1) as appropriate.

A.2.2 Allow the test specimen to remain in the quiescent no-load condition for at least 60 min. Apply a force of 1 N less than the rated holding force and report whether the test specimen releases.

A.2.3 Remove the force, increase the supply voltage or operating pressure to the maximum specified in 7.3.2 or item (d) of 6.1 as appropriate, and allow the test specimen to remain in the quiescent no-load condition for at least 60 min. Apply a force of 1 N more than the maximum holding force (see 6.4 (a)) and record whether the test specimen releases.

A.2.4 Connect the test specimen to the nominal supply voltage (see 7.3.1) or nominal operating pressure (see item (d) of 6.1) as appropriate.

A.2.5 Apply the appropriate maximum residual holding force (see table 2) for 4 h. Disconnect the power supply (or release the supply pressure) and record whether the test specimen releases within 4.0 s.

Publications referred to

- BS 302 Stranded steel wire ropes
Part 2 Specification for ropes for general purposes
- BS 2011 Basic environmental testing procedures
Part 1.1 General and guidance
Part 2.1A. Test A. Cold
Part 2.1Ca. Test Ca. Damp heat, steady state
Part 2.1Fc. Test Fc. Vibration (sinusoidal)
Part 2.1Kc. Test Kc. Sulphur dioxide test for contacts and connections
Section 4.1 Specification for mounting of components, equipment and other articles for dynamic tests
- BS 3955 Specification for electrical controls for household and similar general purposes
- BS 4575 Fluid power transmission and control systems
Part 1 Guide for hydraulic equipment and systems
- *BS 5345 Code of practice for the selection, installation, and maintenance of electrical apparatus for use in potentially explosive atmospheres (other than mining applications or explosive processing and manufacture)
- BS 5490 Specification for classification of degrees of protection provided by enclosures
- *BS 5750 Quality systems
- BS 5839 Fire detection and alarm systems for buildings
Part 1 Code of practice for system design, installation and servicing
- BS 6459 Door closers
- *BS EN 1155 Building hardware — Electrically powered hold-open devices for swing doors — Requirements and test methods

*Referred to in the foreword only.

This British Standard, having been prepared under the direction of the Fire Standards Committee, was published under the authority of the Board of BSI and comes into effect on 29 April 1988.

© British Standards Institution, 1998

ISBN 0 580 15787 3

The following BSI references relate to the work on this standard: Committee reference FSM/12 Draft for comment 82/11073 DC.

BSI is the independent national body responsible for preparing British Standards. It presents the UK review on standards in Europe and at the international level. It is incorporated by Royal Charter.

Revisions

British Standards are updated by amendment or revision. Users of British Standards should make sure that they possess the latest amendments or editions.

It is the constant aim of BSI to improve the quality of our products and services. We would be grateful if anyone finding an inaccuracy or ambiguity while using this British Standard would inform the Secretary of the responsible technical committee, the identity of which can be found on the inside front cover. Tel: 0181 996 9000; Fax: 0181 996 7400.

BSI offers members an individual updating service called PLUS which ensures that subscribers automatically receive the latest editions of standards.

Buying standards

Orders for all BSI, international and foreign standards publications should be addressed to Customer Services. Tel: 0181 996 7000; Fax: 0181 996 7001.

In response to orders for international standards, it is BSI policy to supply the BSI implementation of those that have been published as British Standards, unless otherwise requested.

Information on standards

BSI provides a wide range of information on national, European and international standards through its Library and its Technical Help to Exporters Service. Contact the Information Centre. Tel: 0181 996 7111; Fax: 0181 996 7048.

Subscribing members of BSI are kept up to date with standards developments and receive substantial discounts on the purchase price of standards. For details of these and other benefits contact Membership Administration. Tel: 0181 996 7002; Fax: 0181 996 7001.

Copyright

Copyright subsists in all BSI publications. BSI also holds the copyright, in the UK, of the publications of the international standardization bodies. Except as permitted under the Copyright, Designs and Patents Act 1988 no extract may be reproduced, stored in a retrieval system or transmitted in any form or by any means – electronic, photocopying, recording or otherwise – without prior written permission from BSI.

This does not preclude the free use, in the course of implementing the standard, of necessary details such as symbols, and size, type or grade designations. If these details are to be used for any other purpose than implementation then the prior written permission of BSI must be obtained.

If permission is granted, the terms may include royalty payments or a licensing agreement. Details and advice can be obtained from the Copyright Manager. Tel: 0181 996 7070.

Committees responsible for this British Standard

The preparation of this British Standard was entrusted by the Fire Standards Committee (FSM/-) to Technical Committee FSM/12, upon which the following bodies were represented:

British Fire Protection Systems Association Ltd.
British Telecommunications plc
Chartered Institution of Building Services Engineers
Chief and Assistant Chief Fire Officers' Association
Department of Health and Social Security
Department of the Environment (Building Research Establishment (Fire Research Station))
Department of the Environment (Property Services Agency)
Department of Transport (Marine Directorate)

Electrical Contractors' Association
Electrical Installation Equipment Manufacturers' Association (BEAMA Ltd.)
Fire Insurers' Research and Testing Organisation (FIRTO)
Fire Offices Committee
Fire Protection Association
Home Office
Institution of Electrical Engineers
Institution of Fire Engineers
Ministry of Defence
National Inspection Council for Electrical Installation Contracting
Royal Institute of British Architects
Society of Fire Protection Engineers
Trades Union Congress

Amendments issued since publication

Amd. No.	Date	Text affected
10207	November 1998	Insertion of note in foreword

British Standards Institution · 389 Chiswick High Road London W4 4AL · Telephone 0181 996 9000 · Fax 0181 996 7400