

# High-strength hexagon nuts

with large widths across flats for structural steel bolting

**DIN**  
**6915**

Sechskantmuttern mit großen Schlüsselweiten für Verbindungen mit HV-Schrauben in Stahlkonstruktionen

Supersedes March 1979 edition.

*In keeping with current practice in standards published by the International Organization for Standardization (ISO), a comma has been used throughout as the decimal marker.*

Dimensions in mm

## 1 Scope and field of application

Hexagon nuts as specified in this standard are intended for use in GV and SL structural steel bolting in accordance with DIN 18 800 Part 1, together with DIN 6914 bolts.

## 2 Dimensions

The nuts shall be countersunk at an angle of  $120^\circ$  on both sides to the screw thread diameter,  $d$ .

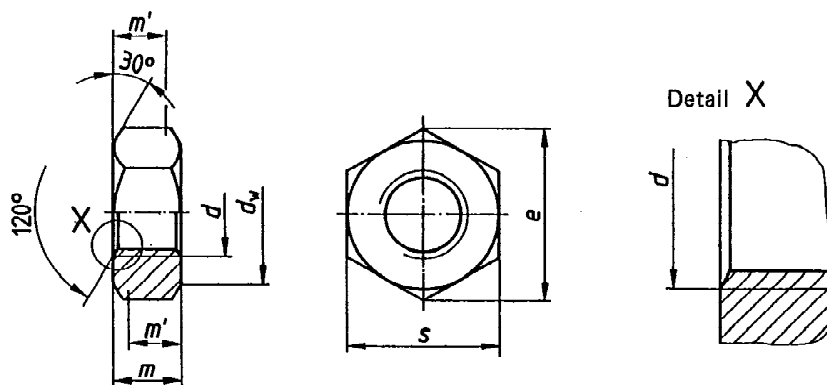

$m'$  = minimum wrenching height (equal to  $0,8 m_{\min}$ ).

Thread size ( $d$ )	M 12	M 16	M 20	M 22	M 24	M 27	M 30	M 36
$P$	1,75	2	2,5	2,5	3	3	3,5	4
$d_w^{1)}$ min.	20	25	30	34	39	43,5	47,5	57
$e$ min.	23,91	29,56	35,03	39,55	45,20	50,85	55,37	66,44
$m$ max. = nominal size	10	13	16	18	19	22	24	29
min.	9,64	12,3	14,9	16,9	17,7	20,7	22,7	27,7
$m'$ min.	7,71	9,84	11,92	13,52	14,16	16,56	18,16	22,16
$s$ max. = nominal size	22	27	32	36	41	46	50	60
min.	21,16	26,16	31	35	40	45	49	58,8
Mass ( $7,85 \text{ kg/dm}^3$ ), in kg per 1000 units, $\approx$	23,3	44,8	73,9	104	155	224	300	515

1) The maximum value of  $d_w$  shall not exceed the actual width across flats.

Continued on pages 2 and 3

No part of this standard may be reproduced without the prior permission of DIN Deutsches Institut für Normung e. V., Berlin. In case of doubt, the German-language original should be consulted as the authoritative text.

**3 Technical delivery conditions**

Material		Steel
General requirements		As specified in DIN 267 Part 1.
Thread	Tolerance	6 H
	As specified in	DIN 13 Parts 12 and 15.
Mechanical properties <sup>1)</sup>	Property class	10
	As specified in	DIN 267 Part 4.
Limit deviations and geometrical tolerances	Product grade	B
	As specified in	ISO 4759 Part 1.
Surface finish	As processed. DIN 267 Part 2 shall apply with regard to surface roughness. DIN 267 Part 21 shall apply with regard to the ductility of nuts. DIN 267 Part 20 shall apply with regard to permissible surface discontinuities. DIN 267 Part 10 shall apply with regard to hot dip galvanizing.	
Acceptance inspection	DIN 267 Part 5 shall apply with regard to acceptance inspection.	
1) Steel bolt/nut assemblies using DIN 6914 screws and DIN 6915 nuts are designed to comply with the requirement that in the case of failure of an adequately lubricated assembly due to overtightening, stripping of the threads is to occur rather than fracture of the bolt.		

**4 Designation**

Designation of an M 20 hexagon nut with large width across flats:

Hexagon nut DIN 6915 – M 20

The DIN 4000 – 2 – 7 tabular layout of article characteristics shall apply to nuts covered in this standard.

**5 Marking**

Nuts shall be marked in accordance with DIN 267 Part 4 and shall additionally bear the symbol 'HV' on one of its faces.

**Standards referred to**

DIN	13 Part 12	ISO metric screw threads; coarse and fine pitch threads from 1 to 300 mm diameter; selection of diameters and pitches
DIN	13 Part 15	ISO metric screw threads; fundamental deviations and tolerances for screw threads of 1 mm diameter and larger
DIN	267 Part 1	Fasteners; technical delivery conditions; general requirements
DIN	267 Part 2	Fasteners; technical delivery conditions; finish and dimensional accuracy
DIN	267 Part 4	Fasteners; technical delivery conditions; property classes for nuts (previous classes)
DIN	267 Part 5	Fasteners; technical delivery conditions; acceptance inspection (modified version of ISO 3269, 1984 edition)
DIN	267 Part 10	Fasteners; technical delivery conditions; hot dip galvanized components
DIN	267 Part 20	Fasteners; technical delivery conditions; surface discontinuities on nuts
DIN	267 Part 21	Fasteners; technical delivery conditions; widening test on nuts
DIN	4000 Part 2	Tabular layout of article characteristics for bolts, screws and nuts
DIN	6914	High-strength hexagon bolts with large widths across flats for structural steel bolting
DIN	18 800 Part 1	Steel structures; design and construction
ISO	4759 Part 1	Tolerances for fasteners; bolts, screws and nuts with thread diameters $\geq 1,6$ and $\leq 150$ mm; product grades A, B and C

**Previous editions**

DIN 6915: 08.62, 01.71, 03.79.

**Amendments**

The following amendments have been made to the March 1979 edition:

- a) Limits of size are now specified.
- b) Electroplating as specified in DIN 267 Part 9 is no longer specified.
- c) The standard has been editorially revised.

**International Patent Classification**

E 04 B 1/38  
F 16 B 37/00  
F 16 B 5/02