**Petroleum and natural gas industries —
Evaluation and testing of thread
compounds for use with casing, tubing,
line pipe and drill stem elements**

*Industries du pétrole et du gaz naturel — Évaluation et essais des
graisses pour filetage utilisées pour les tubes de cuvelage, les tubes de
production, les tubes de conduites et les éléments de garnitures de
forage*



Reference number
ISO 13678:2009(E)

© ISO 2009

PDF disclaimer

This PDF file may contain embedded typefaces. In accordance with Adobe's licensing policy, this file may be printed or viewed but shall not be edited unless the typefaces which are embedded are licensed to and installed on the computer performing the editing. In downloading this file, parties accept therein the responsibility of not infringing Adobe's licensing policy. The ISO Central Secretariat accepts no liability in this area.

Adobe is a trademark of Adobe Systems Incorporated.

Details of the software products used to create this PDF file can be found in the General Info relative to the file; the PDF-creation parameters were optimized for printing. Every care has been taken to ensure that the file is suitable for use by ISO member bodies. In the unlikely event that a problem relating to it is found, please inform the Central Secretariat at the address given below.



COPYRIGHT PROTECTED DOCUMENT

© ISO 2009

All rights reserved. Unless otherwise specified, no part of this publication may be reproduced or utilized in any form or by any means, electronic or mechanical, including photocopying and microfilm, without permission in writing from either ISO at the address below or ISO's member body in the country of the requester.

ISO copyright office
Case postale 56 • CH-1211 Geneva 20
Tel. + 41 22 749 01 11
Fax + 41 22 749 09 47
E-mail copyright@iso.org
Web www.iso.org

Published in Switzerland

Contents

Page

Foreword.....	iv
Introduction	v
1 Scope	1
2 Conformance	1
2.1 Dual citing of normative references.....	1
2.2 Units of measurement	1
3 Normative references	2
4 Terms and definitions	3
5 Thread compound characteristics	4
5.1 Product characteristics	4
5.2 Physical and chemical characteristics	5
6 Thread compound performance properties	9
6.1 Small-scale test.....	9
6.2 Frictional properties	9
6.3 Extreme surface-contact pressure (gall resistance) properties for casing, tubing and line pipe.....	10
6.4 Fluid sealing properties for casing, tubing and line pipe.....	11
7 Quality assurance and control	11
8 Marking requirements	12
8.1 Marking	12
8.2 Labelling	12
Annex A (informative) API modified thread compound.....	13
Annex B (normative) Casing, tubing and line pipe reference standard formulation	17
Annex C (normative) Penetration test.....	19
Annex D (normative) Evaporation test.....	20
Annex E (normative) Oil separation test.....	21
Annex F (normative) Application/adherence test	22
Annex G (normative) Gas evolution test.....	23
Annex H (normative) Water leaching test.....	27
Annex I (informative) Frictional properties test	30
Annex J (informative) Extreme surface-contact pressure (galling) test for casing, tubing and line pipe.....	40
Annex K (informative) Fluid sealing test for casing, tubing and line pipe	41
Annex L (informative) Corrosion inhibition tests.....	44
Annex M (informative) Compound high-temperature stability test.....	45
Bibliography	46

Foreword

ISO (the International Organization for Standardization) is a worldwide federation of national standards bodies (ISO member bodies). The work of preparing International Standards is normally carried out through ISO technical committees. Each member body interested in a subject for which a technical committee has been established has the right to be represented on that committee. International organizations, governmental and non-governmental, in liaison with ISO, also take part in the work. ISO collaborates closely with the International Electrotechnical Commission (IEC) on all matters of electrotechnical standardization.

International Standards are drafted in accordance with the rules given in the ISO/IEC Directives, Part 2.

The main task of technical committees is to prepare International Standards. Draft International Standards adopted by the technical committees are circulated to the member bodies for voting. Publication as an International Standard requires approval by at least 75 % of the member bodies casting a vote.

Attention is drawn to the possibility that some of the elements of this document may be the subject of patent rights. ISO shall not be held responsible for identifying any or all such patent rights.

ISO 13678 was prepared by Technical Committee ISO/TC 67, *Materials, equipment and offshore structures for petroleum, petrochemical and natural gas industries*, Subcommittee SC 5, *Casing, tubing and drill pipe*.

This second edition cancels and replaces the first edition (ISO 13678:2000), which has been technically revised.

It is the intent of ISO/TC 67 that the first and second editions of ISO 13678 both be applicable, at the option of the purchaser, for a period of six months from the first day of the calendar quarter immediately following the date of publication of this second edition, after which period the first edition will no longer be applicable.

Introduction

This International Standard is based on API RP 5A3 ^[5], second edition, July 2003, with errata and inclusion of all clauses of API RP 7A1¹⁾ ^[6], first edition, November 1992, incorporated into Annex I.

This International Standard specifies requirements and gives recommendations for the manufacture, testing and selection of thread compounds for use on casing, tubing, line pipe and drill stem elements based on the current industry consensus of good engineering practice.

It is intended that the words casing and tubing apply to the service application, rather than to the diameter of the pipe.

The performance requirements of thread compounds for use with casing, tubing, line pipe, premium connections and rotary shouldered connections include:

- consistent frictional properties that allow both proper and uniform connection engagement;
- adequate lubrication properties to resist galling or damage of connection contact surfaces during make-up and breakout;
- adequate sealing properties for thread-type seal connections and/or not inhibiting the sealing properties of non-thread sealing connections (e.g. metal-to-metal seals, polytetrafluoroethylene (PTFE) seals, etc.) depending upon service requirements;
- physical and chemical stability both in service and in expected compound storage conditions;
- properties that allow effective application to the connection contact surfaces in expected service conditions and environment.

In addition, compounds for rotary shouldered connections provide:

- lubrication of the connection members during make-up to achieve the proper axial bearing stress;
- an effective seal between connection shoulders to prevent wash-out by drilling fluids;
- more uniform distribution of circumferential bearing stress if shoulders are not parallel;
- resistance to additional make-up down hole.

When evaluating the suitability of a thread compound, the user can define the service conditions and then consider field trials and field service experience in addition to laboratory test results. Appropriate supplementary tests can be utilized for specific applications which are not evaluated by the tests herein. The user and manufacturer are encouraged to discuss service applications and limitations of the compound being considered.

Representatives of users and/or other third party personnel are encouraged to monitor tests wherever possible. Interpolation and extrapolation of test results to other products, even of similar chemical composition, is not recommended.

1) Obsolete. Incorporated into this International Standard.

ISO 13678:2009(E)

Testing in compliance with this International Standard does not in and of itself ensure adequate thread compound/connection system performance in field service. The user has the responsibility of evaluating the results obtained from the recommended procedures and test protocols and determining whether the thread compound/connection system in question meets the anticipated requirements of that particular field service application.

Petroleum and natural gas industries — Evaluation and testing of thread compounds for use with casing, tubing, line pipe and drill stem elements

1 Scope

This International Standard provides requirements, recommendations and methods for the testing of thread compounds intended for use on ISO/API thread forms, as well as proprietary casing, tubing, line pipe and drill stem elements with rotary shouldered connections. The tests outlined are used to evaluate the critical performance properties and physical and chemical characteristics of thread compounds under laboratory conditions.

These test methods are primarily intended for thread compounds formulated with a lubricating base grease and are not applicable to some materials used for lubricating and/or sealing thread connections. It is recognized that many areas can have environmental requirements for products of this type. This International Standard does not include requirements for environmental compliance. It is the responsibility of the end user to investigate these requirements and to select, use and dispose of the thread compounds and related waste materials accordingly.

2 Conformance

2.1 Dual citing of normative references

In the interests of world-wide application of this International Standard, Technical Committee ISO/TC 67 has decided, after detailed technical analysis, that certain of the normative documents listed in Clause 3 and prepared by ISO/TC 67 or another ISO Technical Committee are interchangeable in the context of the relevant requirement with the relevant document prepared by the American Petroleum Institute (API), the American Society for Testing and Materials (ASTM) and the American National Standards Institute (ANSI). These latter documents are cited in the running text following the ISO reference and preceded by “or”, for example “ISO XXXX or API YYYY”. Application of an alternative normative document cited in this manner will lead to technical results different from the use of the preceding ISO reference. However, both results are acceptable and these documents are thus considered interchangeable in practice.

2.2 Units of measurement

In this International Standard, data are expressed in both the International System (SI) of units and the United States Customary (USC) system of units. For a specific order item, it is intended that only one system of units be used, without combining data expressed in the other system.

Products manufactured to specifications expressed in either of these unit systems shall be considered equivalent and totally interchangeable. Consequently, compliance with the requirements of this International Standard as expressed in one system provides compliance with requirements expressed in the other system.

For data expressed in the SI system, a comma is used as the decimal separator and a space as the thousands separator. For data expressed in the USC system, a dot (on the line) is used as the decimal separator and a space as the thousands separator. In the text, data in SI units are followed by data in USC units in parentheses.

3 Normative references

The following referenced documents are indispensable for the application of this document. For dated references, only the edition cited applies. For undated references, the latest edition of the referenced document (including any amendments) applies.

ISO 2137, *Petroleum products and lubricants — Determination of cone penetration of lubricating greases and petrolatum*

ISO 2176, *Petroleum products — Lubricating grease — Determination of dropping point*

ISO/TR 10400, *Petroleum and natural gas industries — Equations and calculations for the properties of casing, tubing, drill pipe and line pipe used as casing or tubing*

ISO 10405, *Petroleum and natural gas industries — Care and use of casing and tubing*

ISO 13679, *Petroleum and natural gas industries — Procedures for testing casing and tubing connections*

ANSI/API BUL 5C3, *Bulletin on formulas and calculations for casing, tubing, drill pipe, and line pipe properties*

API RP 5C1, *Recommended practice for care and use of casing and tubing*

API RP 5C5, *Recommended practice on procedures for testing casing and tubing connections*

API RP 7G, *Recommended practice for drill stem design and operating limits*

ASTM D217, *Standard Test Methods for Cone Penetration of Lubricating Grease*

ASTM D2265, *Standard Test Method for Dropping Point of Lubricating Grease over Wide Temperature Range*

ASTM D4048, *Standard Test Method for Detection of Copper Corrosion from Lubricating Grease*

4 Terms and definitions

For the purposes of this document, the following terms and definitions apply.

4.1

API connection

pipe assembly consisting of two external threaded connectors (pins) and a coupling with two internal threaded connectors (box) or one pin and an integral box manufactured in accordance with ISO/API specifications

4.2

API modified thread compound

compound designated as “modified thread compound” in API BUL 5A2

NOTE API BUL 5A2 [4] is obsolete and has been replaced by API RP 5A3 [5].

4.3

box

connector with internal threads

4.4

CT and LP

casing, tubing and line pipe

production and delivery tubulars

4.5

drill stem elements

components of the drilling assembly from the swivel or top drive to the bit, composed of the kelly, drill string, subs, drill collars and other down hole tools such as stabilizers and reamers, also commonly referred to as rotary shouldered connections

4.6

pin

connector with external threads

4.7

premium connection

connection with or without metal-to-metal seal(s) that can provide greater clearance and/or higher performance properties when compared to the API connections

4.8

proprietary connection

connection, without published specifications, made and marketed by companies with exclusive rights to manufacture and/or sell

4.9

reference standard formulation

⟨casing, tubing and line pipe (CT and LP)⟩ thread compound formulated in accordance with the requirements of Annex B, to include the limitations and tolerances in Tables B.1, B.2 and B.3

4.10

reference standard formulation

⟨rotary shouldered connection⟩ thread compound formulated in accordance with the requirements of I.4.2.3

NOTE The reference standard formulations are not intended for general field service.

4.11

rotary shouldered connection

RSC

connection used on drill stem elements, which has threads and sealing shoulders

4.12

seal

barrier resisting the passage of fluids, gases and liquids

4.13

storage compound

substance applied to threaded pipe connections for protection against corrosion, during shipment and/or storage only, that is not used for connection make-up

4.14

thread compound

substance applied to threaded pipe connections prior to make-up for lubrication during assembly and disassembly and for assistance in sealing internal and external pressures

NOTE Some thread compounds can also contain substances that provide storage compound properties.

4.15

thread compound/connection system

system consisting of the various critical threaded pipe connection components, including the specific connection geometry and the individual connection materials and coatings combined with the thread compound

4.16

tool joint

threaded connector used to join sections of drill pipe

5 Thread compound characteristics

5.1 Product characteristics

This International Standard outlines tests to characterize the performance of thread compounds under service conditions, rather than specifying the formulation. Thus, the purchaser and the manufacturer should agree on the product characteristics to be provided, such as:

Thickener type	Rheological properties
Fluid type	Compound/copper reaction
Appearance	Extreme-pressure properties
Dropping point	Fluid sealing properties
Mass density	Frictional properties
Oil separation	Corrosion inhibition
Flash point	Brushing/Adherence
Water-absorption resistance	Service applications
Gas evolution	Storage and service life limitations

The thread compound manufacturer shall revise product bulletins when any modification in formulation is implemented which would result in a change of any critical performance characteristics. All documentation shall provide data which are representative of a typical production batch.

Test and inspection records generated under this International Standard shall be retained by the manufacturer and shall be available to the purchaser for a minimum of three years after the date of manufacture.

5.2 Physical and chemical characteristics

5.2.1 General

The physical and chemical characteristics of performance-based thread compounds are specified in Table 1. These properties can vary widely and the formulation of many of the available compounds is proprietary. Therefore, the user should consider the performance properties and recommendations given by the compound manufacturers, in addition to the physical and chemical characteristics outlined in Table 1.

Table 1 — Thread compound physical and chemical characteristics tests

Property ^a		Test method	Performance value ^b	
Dropping point, °C (°F)	M	ISO 2176 or ASTM D2265	138 (280) min.	S
Evaporation, % volume fraction loss 24 h at 100 °C (212 °F)	M	See Annex D	3,75 max.	S
Gas evolution, cm ³ 120 h at 66 °C (151 °F)	M	See Annex G	20 max.	S
Oil separation, % volume fraction 24 h at 100 °C (212 °F) (nickel gauze cone)	M	See Annex E	10,0 max.	S
Penetration, mm × 10 ⁻¹ Worked, 60 strokes at 25 °C (77 °F) Production acceptability range (min. to max.) Worked, 60 strokes at -7 °C (19 °F)	M	See Annex C	± 15 max. Report typical	S R
Mass density, % variance From production mean value	M	Manufacturer's controls	± 5,0 max.	S
Water leaching, % mass fraction loss 2 h at 66 °C (151 °F)	M	See Annex H	5,0 max.	S
Application and adherence Cold application Adherence at 66 °C (151 °F), % mass fraction loss	M	See Annex F	Applies at -7 °C (19 °F) 25 max.	S R R
Copper corrosion Specified corrosion level	M	ASTM D4048	1B or better	R
Corrosion inhibition, % area corrosion 500 h at 38 °C (100 °F)	I	See Annex L	< 1,0	R
Compound stability, 12 months storage Penetration change, mm × 10 ⁻¹ Oil separation, % volume fraction	M	Manufacturer's controls See Annex C See Annex E	± 30 max. 10,0 max.	R R
Compound stability, field service 24 h at 138 °C (280 °F), % volume fraction loss	I	See Annex M	25,0 max.	R
NOTE The values in this table are not intended to be consistent with Table A.3, which presents the original values and requirements of API BUL 5A2 (obsolete, replaced by API RP 5A3). They have been revised to take into account the high-temperature requirements of current field operating conditions and the mass density variations between different proprietary thread compound formulations.				
^a M mandatory I informative ^b S specification R recommendation				

5.2.2 Dropping point

The dropping point test measures the tendency of grease to soften and flow when hot. Results of the dropping point test may be used as an indication of the maximum temperature to which a grease can be exposed without liquefaction or oil separation, for indication of the type of grease and for establishment of manufacturing or quality control limits for this characteristic. Results are not considered as having any direct bearing on service performance unless such correlation has been established.

In the case of a thread compound, the dropping point is considered to be an indicator of the thermal stability of the base grease and other lubricant additives. Poor thermal stability could adversely affect thread compound performance in high-temperature field service. In order to meet present-day requirements for high temperature service, the minimum dropping point temperature shall be 138 °C (280 °F), as measured in accordance with ISO 2176 or ASTM D2265.

NOTE Extreme-temperature field-service conditions can require a higher performance limit.

5.2.3 Evaporation

The evaporation test indicates a thread compound's physical and chemical stability at elevated temperatures, which is related to the base grease/oil or other additives. Due to the wide variation in mass density of thread compounds currently in service, percentage mass fraction does not provide a reliable basis for comparison; therefore, evaporation loss shall be measured as a percentage volume fraction. The evaporative loss, when evaluated in accordance with the test method in Annex D for a 24 h duration at a temperature of 100 °C (212 °F), shall not exceed 3,75 % volume fraction.

5.2.4 Gas evolution

The gas evolution test indicates a thread compound's chemical stability at elevated temperatures. When evaluated in accordance with the test method in Annex G, the volume of gas evolution shall not exceed 20 cm³.

5.2.5 Oil separation

The oil separation test indicates a compound's physical and chemical stability at elevated temperatures, which is related to the base grease/oil. Due to the wide variation in mass density of thread compounds currently in service, percentage mass fraction does not provide a reliable basis for comparison; therefore, oil separation loss shall be measured as a percentage volume fraction. In order to meet current requirements for high-temperature service, the maximum oil separation loss when evaluated in accordance with the test method in Annex E shall be 10,0 % volume fraction.

5.2.6 Penetration

The penetration test measures the consistency, i.e. "thickness" or "stiffness" of a lubricating grease and relates to the ease of application or "brushability" of a thread compound. The compound manufacturer shall measure and record the penetration of each production batch of thread compound and report the mean value for that specific compound. When evaluated in accordance with the test method in Annex C, the penetration acceptability range (minimum to maximum) at 25 °C (77 °F) shall not be greater than 30 cone penetration points. An acceptability range for penetrations is used because thread compounds with penetrations between 265 and 385 can be used for different applications. For information purposes, cold temperature penetration, at -7 °C (19 °F), is reported as a typical value. Mass density affects the values obtained from this procedure. Therefore, it is not a useful measurement for relative comparisons of materials with widely varying mass densities.

NOTE Brookfield viscosity (ASTM D2196^[19]) is not substantially affected by material mass density and therefore can provide a closer correlation to brushability than the cone penetration. The range below was determined using several different supplier samples of API modified thread compound as well as proprietary thread compounds used currently with casing, tubing and line pipe connections. It is appropriate that a specific spindle size, rotational frequency and test temperature be utilized to develop viscosity data for comparison. The Brookfield viscosity range, as measured with a #7 Spindle, at 10 r/min and 25 °C, was 200 000 mPa·s to 400 000 mPa·s. A typical value for API modified thread compounds could range from 200 000 mPa·s to 240 000 mPa·s.

The SI unit of viscosity is the pascal second (Pa·s). The pascal second is rarely used in scientific and technical publications today. The most common unit of viscosity is the dyne second per square centimetre (dyne·s/cm²), which is given the name poise (P) after the French physiologist Jean Louis Poiseuille (1799–1869). Ten poise equal one pascal second (Pa·s) making the centipoise (cP) and millipascal second (mPa·s) identical.

1 pascal second = 10 poise = 1 000 millipascal second

1 centipoise = 1 millipascal second

5.2.7 Mass density

The mass density test result of a thread compound depends on the type and quantity of the constituents utilized in the formulation. The range of mass density between production batches for a particular thread compound is an indication of the consistency of manufacture. The compound manufacturer shall measure and record the mass density of each production batch of thread compound and report the mean value for that specific compound. The mass density of a particular thread compound batch shall not vary more than 5,0 % from the manufacturer's established mean value.

5.2.8 Water leaching

The water leaching test indicates the physical and chemical stability of compounds when exposed to water at elevated temperatures. When evaluated in accordance with the test method in Annex H, the compound mass loss shall not exceed 5,0 %.

5.2.9 Application and adherence properties

Thread compounds should be applied in a manner consistent with the compound manufacturer and thread manufacturer's recommendations and in sufficient quantity to provide effective lubrication and/or sealing characteristics for threaded connections. The thread compound shall be brushable and capable of adherence over a temperature range of –7 °C (19 °F) to 66 °C (151 °F) without either agglomerating or sliding off the connector.

Laboratory tests for determining the thread compound application and adherence properties shall be performed and recorded. The laboratory test methods described in Annex F are intended to provide a means for comparing thread compound performance, but it is possible for them not to be representative of field service.

5.2.10 Corrosion inhibition and protection properties

Thread compounds are often utilized to provide shipping and storage corrosion protection on threaded connections, as well as lubrication and sealing properties. Certain field exposure conditions, particularly on offshore platforms and in-service conditions such as sour gas environments, require corrosion protection and inhibition. Therefore, the thread compounds with corrosion protection shall provide an effective barrier against (and not contribute to) corrosive attack of connection threads and seals. The corrosion-inhibition properties of thread compounds depend on application variables such as the following:

- compound additive types and treatment levels;
- type and condition of threading process fluids and residue remaining on thread surfaces;
- compound application method and equipment utilized;
- type of thread protector and application method (“knock-on” or “screw-on”);
- specific user application procedures and environmental conditions;
- compatibility with thread storage compound;
- galvanic differences between compound components, environment and connector material.

A laboratory test shall be performed and recorded to determine whether potentially corrosive components are present in the thread compound. A copper corrosion test should be carried out in accordance with the procedures in ASTM D4048 or equivalent. Although copper is not typically utilized (other than as a thread surface plating) in production connections, it more readily reacts in the presence of reactive materials such as sulfur and chlorine, which can also damage steel. Thread compounds should provide a level 1B or better by this method. For RSCs, if thread compounds with metallic zinc are used, it is recommended that active sulfur be limited to less than 0,3 %.

A laboratory test for determining the thread compound corrosion-inhibition properties should be performed and recorded.

Thread compounds vary as to the existence and treatment level of corrosion inhibition. It is, therefore, the purchaser's/user's responsibility to outline the necessary requirements with the compound manufacturer for products being utilized for storage or corrosive field applications. The methods listed in Annex L are generally accepted and utilized by lubricant test laboratories and users. They are intended to provide a means for the relative comparison of thread compound properties.

5.2.11 Compound stability properties

Thread compound stability, both in storage and in service, is a property essential to adequate sealing performance within an assembled connection. Instability in the form of excessive softening and separation can result in the development of leak passages over time or with changes in temperature. Excessive hardening in storage can adversely affect brushability and proper application of the compound onto the pipe thread surfaces.

The compound manufacturer shall keep production batch samples and evaluate them periodically for storage stability. Thread compound storage stability over a minimum of 12 months is adequate to resist softening or hardening of more than 30 cone penetration points at 25 °C (77 °F), when evaluated in accordance with the test method in Annex C. Stratification or oil separation should not be greater than 10,0 % volume fraction over a minimum period of 12 months. The test described in Annex M should also be performed and is intended to provide a means for the relative comparison of thread compound high-temperature stability.

Thread compound stability test results shall be available in a product bulletin.

6 Thread compound performance properties

6.1 Small-scale test

The small-scale (bench top) test described in 1.4 compares the friction properties of a test compound to a lead-based reference compound formulated for laboratory use. There is a possibility that small-scale tests might not correlate directly with full-scale connection tests or be truly representative of field service. Annex I [formerly API RP 7A1 ^[6] (obsolete)] covers a small-scale test procedure that was developed and validated utilizing the metal-based RSC compounds that were commonly used in field applications in the early 1990s. Subsequent industry test programmes utilizing non-metallic RSC compounds have shown limited correlation of small-scale test frictional properties with full-scale test results. Therefore, this test method has limited usefulness for determining friction factors for non-metallic compounds for use on any type of connection.

6.2 Frictional properties

A thread compound acts as a lubricant during make-up and breakout and provides consistent and repeatable frictional properties between the mating members of a threaded connection. For a given amount of connection engagement (a specific number of engaged threads), the torque required varies in direct proportion to the apparent coefficient of friction of the thread compound/connection system. The frictional properties of the thread compound/connection system affect the following torque values:

- the torque required to make up the connection;

- the torque required to cause further make-up;
- the torque required to break out the connection.

The frictional properties of a thread compound in a connection also depend on several factors external to the compound. These external factors include connection geometry, machined surface finish, coating of the contact surfaces, relative surface speed (make-up revolutions per minute) of the connection members during make-up, compound film thickness and surface contact pressure. Each of these parameters should be taken into account when designing a test to determine frictional properties and when using a compound in the field.

A laboratory test, such as described in Annex I, for determining the thread compound frictional properties should be performed and recorded. The laboratory test methods described in Annex I are intended to provide a means of comparing thread compounds with the specified reference standard formulations.

In the case of casing, tubing and line pipe, if different thread compounds are applied to opposite ends of a coupling, frictional differences can occur between the mill end connection and the field end connection and can result in excessive movement and engagement of the mill end prior to adequate engagement of the field end. The field torque required for proper assembly of API-type connections should be determined in accordance with the procedures described in ISO 10405 or as recommended by the connection manufacturer.

6.3 Extreme surface-contact pressure (gall resistance) properties for casing, tubing and line pipe

A thread compound provides resistance to adhesive wear (metal galling) of the mating connection surfaces subjected to extreme surface-contact pressure.

High surface-contact pressure in threaded connections can occur as a result of various factors during manufacturing and in field service. Manufacturing factors include product variations, such as geometric characteristics (thread length, pipe and coupling thicknesses) and process variations, such as machining (thread taper, lead and flank angles), surface finishing and coating. Field service factors include handling damage, contact-surface contamination, inadequate or inconsistent application of thread compound, misalignment during assembly and improper torque application.

An important consideration is the greater tendency of some materials towards connection galling than others. Galling tendency increases between two smooth metal surfaces with increasing similarities of composition, similarities of relative hardness and decreasing actual hardness. For OCTG (Oil Country Tubular Goods), the composition and hardness of each component of the mating pair is virtually the same. Consequently, OCTG are relatively prone to galling. Therefore, a coating for one of the connection members, such as zinc phosphate and manganese phosphate and API modified thread compound, has traditionally been utilized to provide adequate galling resistance.

The increasing use of quench-hardened alloys and the significantly greater tendency of martensitic chromium steels, duplex stainless steels and nickel-based alloys to galling requires that all possible care be applied to every aspect of surface preparation: coating, thread compound selection and application, handling and connection assembly to achieve connection galling resistance.

A laboratory test such as described in Annex J for determining the total thread compound/connection system extreme surface-contact pressure properties (gall resistance) should be performed and the results recorded. The laboratory test methods described in Annex J are intended to provide a means for comparing thread compounds with the reference standard, described in Annex B.

For specific service applications, the total thread compound connection system should be evaluated for galling resistance. This requires repeated assembly and disassembly tests on full-scale connections, preferably in the vertical mode, to simulate rig assemblies, with minimum and maximum amounts of thread compound. Such tests should be performed in accordance with the industry test methods referenced in Annex J.

Connections with inadequate surface preparation can not resist galling, regardless of handling or assembly technique. Conversely, connections with adequate surface preparation can be galled with inadequate handling or assembly technique. Each activity should be controlled to achieve repeatable extreme pressure properties.

The combination of proper surface preparation, connection coating and thread compound selection and application should be established for each type of connection and material combination, based on their tendency to gall, during both assembly and disassembly following service.

6.4 Fluid sealing properties for casing, tubing and line pipe

When used on thread-sealing connections, a thread compound provides fluid sealing for thread clearances, such as the helical root-to-crest clearances in API 8-round threads and the helical stab flank clearance in API buttress threads. Sealing is typically accomplished in a thread compound with solid particles that agglomerate to plug the thread clearances to prevent the contained fluid from passing through the connection.

Connection sealing also requires that positive contact pressure be maintained along the thread interface in order to ensure the geometric integrity of the helical sealing passages. Contact pressure requirements are established for connection fluid pressure integrity and are given in ISO/TR 10400 or ANSI/API BUL 5C3.

A laboratory test for determining the thread-sealing properties of the thread compound should be performed and the results recorded. The laboratory test methods described in Annex K are intended to provide a means for comparing thread compounds with the CT and LP reference standard formulation, described in Annex B.

For specific service applications, the total thread compound/connection system should be evaluated for fluid-sealing integrity on full-scale connections. While it is important for a thread compound to provide fluid sealing for thread clearances on API connections, it is also important that the thread compounds do not inhibit the sealing integrity of connections with metal-to-metal seals. The solid particles that agglomerate can prohibit the designed mechanical seals (metal-to-metal) from efficiently contacting, resulting in a leakage path. Sealing tests should therefore be conducted on the thread compound/connection system, of which the thread compound is a part. Such tests should be in accordance with the procedures defined in K.3.

7 Quality assurance and control

This International Standard is based on the concept that the function of a thread compound used with threaded connections for ISO/API casing, tubing, line pipe and drill stem elements can be defined by performance properties that include, but are not limited to, friction, extreme surface-contact pressure, thread sealing, adherence and corrosion inhibition, as described in Clauses 5 and 6.

These performance properties are complex and sometimes interrelated and therefore difficult to quantify. Minor differences in product composition, manufacture or application can result in significant changes in performance properties.

For these reasons, the manufacturer shall have a comprehensive system of quality assurance to ensure that the represented properties are maintained throughout the range of variation of raw materials, manufacturing processes and application environment. It is possible for the purchaser to request that the manufacturer furnish a declaration of conformity, stating that the thread compound has been tested and evaluated in accordance with this International Standard and meets or exceeds the specified requirements.

8 Marking requirements

8.1 Marking

A thread compound manufactured and tested in conformance with the requirements of this International Standard shall be marked, on each container, with the manufacturer's identification, traceability identification, manufacture date, shelf-life ending date and one of the following statements:

— **“THIS THREAD COMPOUND CONFORMS WITH ISO 13678 AND IS RECOMMENDED FOR USE WITH CASING, TUBING AND LINE PIPE ”**

or

— **“THIS THREAD COMPOUND CONFORMS WITH ISO 13678 AND IS RECOMMENDED FOR USE WITH ROTARY SHOULDERED CONNECTIONS”**

or

— **“THIS THREAD COMPOUND CONFORMS WITH ISO 13678 AND IS RECOMMENDED FOR USE WITH CASING, TUBING, LINE PIPE AND ROTARY SHOULDERED CONNECTIONS ”**

8.2 Labelling

8.2.1 Unless a storage compound is dually applicable for both thread compound service and storage compound service, the container shall be conspicuously labelled with the following cautionary statement:

— **“STORAGE COMPOUND — NOT RECOMMENDED FOR MAKE-UP”**

8.2.2 Each container shall be conspicuously labelled with cautionary statements regarding storage, preparation or application required to achieve the characteristics disclosed in the product bulletin, including any special thread compound manufacturer's conditions required for storage before use. Two examples are:

— **“STIR WELL BEFORE USING”**

— **“THREAD COMPOUND PLUS INLAND SHORT TERM STORAGE”**

Annex A (informative)

API modified thread compound

A.1 General

Clauses A.2 to A.6 are for information only and are based on API BUL 5A2²⁾ [4] omitting all references to “silicone thread compound”.

A.2 Compound

The compound is designated as the “modified thread compound”. It is a mixture of metallic and graphite powders uniformly dispersed in a grease base. Proportions of solids and grease base are as listed in Table A.1.

Table A.1 — Proportions of solids and grease base

Component	Mass fraction %
Total solids	64,0 ± 2,5
Grease base	36,0 ± 2,5
Total	100,0

A.3 Composition of solids

The solids are a mixture of amorphous graphite, lead powder, zinc dust and copper flake in the proportions listed in Table A.2 and as specified in A.6.1 to A.6.4.

Table A.2 — Proportions of solids

Constituent	Mass fraction %	
	Total solids	Compound
Amorphous graphite	28,0	18,0 ± 1,0
Lead powder	47,5	30,5 ± 0,6
Zinc dust	19,3	12,2 ± 0,6
Copper flake	5,2	3,3 ± 0,3
Total	100,0	64,0

2) API BUL 5A2 is obsolete, replaced by API RP 5A3.

A.4 Grease base

Grease base for the modified thread compound is thickened petroleum oil which, when combined with the powdered metals and graphite, gives a compound which complies with the control and performance test requirements listed in Table A.3.

A.5 Control and performance tests

The thread compound should be subjected to control and performance tests for penetration, dropping point, evaporation, oil separation, gas evolution, water leaching and brushing ability as designated in Table A.3. The thread compound should comply with requirements listed in Table A.3 based on a test specimen which is representative of the entire contents of the container.

Table A.3 — Modified thread compound control and performance tests

Test	Requirement
Penetration, mm × 10 ⁻¹ worked at 25 °C (77 °F) (NLGI ^a No. 1) after cooling at -18 °C (0 °F) (see procedure in Annex C)	310 to 340 200 min.
Dropping point, °C (°F) (ASTM D566 ³⁾ [16])	88 °C (190 °F) min.
Evaporation, % mass fraction 24 h at 100 °C (212 °F) (see Annex D)	2,0 max.
Oil separation, % mass fraction, nickel cone 24 h at 66 °C (151 °F) (see Annex E)	5,0 max.
Gas evolution, cm ³ 120 h at 66 °C (151 °C) (see Annex G)	20 max.
Water leaching, % mass fraction after 2 h at 66 °C (151 °F) (see Annex H)	5,0 max.
Brushing ability (see Annex F)	Applicable at -18 °C (0 °F)
NOTE The information presented in this table applies only to the API modified thread compound formula.	
^a National Lubricating Grease Institute, 4635 Wyandotte Street, Kansas City, MO 64112-1596, USA.	

3) ASTM D2265 may be used in place of ASTM D566.

A.6 Component material requirements

A.6.1 Graphite

Graphite should be a natural amorphous type, free of powdered coal, lamp black, carbon black, oil, grease, grit or other abrasives, or other deleterious materials. It should conform to the following requirements.

Composition (ASTM C561 [11])

Ash, % mass fraction	28 min., 37 max.
----------------------	------------------

Particle size (ASTM E11 [23])

Pass No. 50 sieve, %, min.	100,0
On No. 100 sieve, %, max.	1,0
On No. 200 sieve, %, min.	10,0
Pass No. 325 sieve, %	30 min., 80 max.

A.6.2 Lead powder

Lead powder should conform to the following requirements.

Composition (ASTM D1301 [17])

Free metal content, % mass fraction, min.	95,0
Lead oxide content, % mass fraction, max.	5,0

Particle size (ASTM E11 [23])

Pass No. 50 sieve, % mass fraction, min.	100,0
On No. 100 sieve, % mass fraction, max.	2,0
Pass No. 325 sieve, % mass fraction	30 min., 92 max.

A.6.3 Zinc dust

Zinc dust should be homogeneous. The zinc dust should be so constituted that the finished thread compound can meet the gas evolution test requirements of Table A.3. It should conform to the following requirements.

Composition (ASTM D521 [15])

Total zinc, calculated as Zn, % mass fraction, min.	98,0
Metallic zinc, % mass fraction, min.	95,0
Iron, lead and cadmium, % mass fraction, max.	1,0
Calcium calculated as CaO, % mass fraction, max.	0,5
Moisture and other volatile matter, % mass fraction, max.	0,1
Zinc oxide (ZnO)	Remainder

Particle size (ASTM E11 [23])

Pass No. 100 sieve, % mass fraction, min.	100,0
Pass No. 325 sieve, % mass fraction, min.	90,0

A.6.4 Copper flake

Copper flake should conform to the following requirements.

Composition (ASTM D283 4) [13]

Copper, % mass fraction, min.	97,0
Grinding and polishing compound, % mass fraction, max.	0,25

Particle size (ASTM E11 [23])

Pass No. 200 sieve, % mass fraction, min.	100,0
Pass No. 325 sieve, % mass fraction, min.	99,0
Thickness > 5 µm, % mass fraction, max.	5,0

4) Copper flake conformity was based on ASTM D283, which has been withdrawn and may be replaced by ASTM E478.

Annex B (normative)

Casing, tubing and line pipe reference standard formulation

The following casing, tubing and line pipe (CT and LP) reference standard formulation for thread compound is based on tightening the tolerances of API modified thread compound constituents closer to nominal values. In order to provide the replication required for a reference standard, the CT and LP reference standard formulation tolerances and ranges are shown in Tables B.1, B.2 and B.3.

Table B.1 — Reference standard composition and tolerances

Component	Mass fraction %
Grease base	36,00 ± 1,05
Graphite	18,00 ± 0,30
Lead powder	30,50 ± 0,50
Zinc dust	12,20 ± 0,20
Copper flake	3,30 ± 0,05

The grease base shall conform to the requirements of Table B.2.

Table B.2 — Grease base requirements

Property	Requirement
Consistency	NLGI No. "0"
Worked penetration, mm × 10 ⁻¹ [ISO 2137 (ASTM D217), 60 strokes]	365 to 385
Thickener, % mass fraction, lithium 12-hydroxystearate	2,0 to 4,5
Petroleum oil viscosity, mm ² /s	115 to 170 at 40 °C (104 °F) 9,5 to 14,0 at 100 °C (212 °F)

NOTE API BUL 5A2²⁾ [4] did not specify requirements for the "extreme pressure" performance properties of the base grease utilized in the formulation of API modified thread compound. Commercial formulations however, have included extreme pressure additives because of their recognized benefit in resisting the galling and wear of opposing contact surfaces under high bearing pressures. The additives used by commercial manufacturers, however, can vary substantially in quality and performance. Therefore, the reference standard formulation was specified to exclude those and other additives that can introduce a variable that would adversely affect the direct comparison of the discrete test data. Full-scale test data from a combined API/Joint industry research project (API 1997 [7]) indicate that it would possibly be necessary to include an extreme pressure additive in the formulation of the grease base specified for the reference standard. The average breakout torque for Label 1: 3,5 in N80 tubing exceeded 150 % of the make-up torque when using the reference standard formulated as specified without extreme pressure additives. There was also a high incidence of galling of the test specimen connection members. These problems were addressed by the addition of antimony dialkyldithiocarbamate at the rate of 2,0 % (by mass) to the base grease. This particular extreme pressure additive was chosen because of its wide use in the lubricant industry and its ready availability. The base grease with the addition of the extreme pressure additive exhibited a Four-Ball Weld Point (ASTM D2596 [22]) of 250 kg and a Timken OK Load

(ASTM D2509 [21]) of approximately 9,08 kg. If antimony dialkyldithiocarbamate is not available, the extreme pressure additive that is utilized is added at a rate that yields equivalent results in the ASTM test methods cited.

The solid components shall conform to the requirements of Table B.3.

Table B.3 — Reference standard constituent limitations, percent mass fraction

Test parameter	Amorphous graphite	Copper flake	Lead powder	Zinc dust
Ash	30 to 36	Not available	Not available	Not available
Moisture, max.	1,0	0,1	0,1	0,1
Metallic content, min.	Not available	97,0	95,0	95,0
Metal/Other oxides, max.	Not available	3,0	5,0	5,0
Particle size distribution				
Pass No. 50 sieve, min.	100,0	100,0	100,0	100,0
Retained on No. 100 sieve, max.	0,3	0,0	1,0	0,0
Retained on No. 200 sieve	10,0 to 18,0	0,0	5,0 to 25,0	2,0 max.
Retained on No. 325 sieve	20,0 to 31,0	1,0	14,0 to 55,0	5,0 max.
Pass No. 325 sieve	50,0 to 70,0	99,0	40,0 to 80,0	93,0
NOTE This reference standard compound is not intended for general service.				

Annex C (normative)

Penetration test

C.1 General

This Annex describes a procedure for measuring consistency (stiffness) of thread compound.

C.2 Apparatus

C.2.1 Penetrometer.

C.2.2 Cone, full-scale.

C.2.3 Grease worker.

C.2.4 Spatula.

C.2.5 Cooling chamber, capable of maintaining -7 °C (19 °F) $\pm 1,1\text{ °C}$ (2 °F).

C.3 Procedure

Prepare two samples for worked penetration. After working (60 strokes), determine penetration of the first sample at 25 °C (77 °F) in accordance with ISO 2137 and ASTM D217.

After working the second sample at 25 °C (77 °F), mound excess compound on top of penetration cup and place in cooling chamber along with penetrometer cone for 3 h at -7 °C (19 °F). After the 3 h soaking period, remove cup and strike excess compound flush with the top of cup. Place cup and sample in cooling chamber for an additional hour. Without further working, determine penetration as quickly as possible.

Annex D (normative)

Evaporation test

D.1 General

This annex describes a procedure for measuring losses of volatile materials from thread compound at a temperature of 100 °C (212 °F) under static conditions.

D.2 Apparatus

D.2.1 Evaporating dish, No. 3 Coors, porcelain, shallow form, or its equivalent.

D.2.2 Gravity convection oven, capable of maintaining a test temperature of 100 °C ± 1,1 °C (212 °F ± 2 °F).

D.2.3 Precision balance.

D.2.4 Desiccator.

D.3 Procedure

Weigh a 30 cm³ (approximate) sample into the tared evaporating dish (D.2.1). Place the assembly in an oven (D.2.2) at 100 °C ± 1,1 °C (212 °F ± 2 °F) for 24 h. Then place the sample in a desiccator (D.2.4). Cool, weigh (D.2.3) and report material loss as percent evaporation loss, calculated as percent volume fraction.

To calculate the percent volume fraction, first determine the mass density (kg/m³) of the test compound sample. The mass of the amount required for test is determined either by direct measurement or by subtracting the tare mass of the test equipment containing the sample from the total mass of the sample plus equipment. The volume of the sample in cubic centimetres is then calculated by dividing the sample mass in grams by its mass density and multiplying by 1 000. The oils or volatiles lost by separation or evaporation can be assumed to have an approximate mass density of 900 kg/m³ if they are hydrocarbon based. The volume of the separated/evaporated materials is calculated by dividing the measured mass loss in grams by 900 kg/m³ (or the actual mass density if known to be different) and multiplying by 1 000. The percent volume fraction loss is then calculated by dividing the volume of the separated/evaporated material by the volume of the starting sample and multiplying by 100.

Annex E (normative)

Oil separation test

E.1 General

This annex describes a procedure for measuring the tendency of thread compound to separate oil at 100 °C (212 °F) under static conditions.

E.2 Apparatus

E.2.1 Nickel filter cone⁵⁾ or equivalent, approximately 38 mm in diameter and with sides forming an angle of 60°. The cone shall be perforated with approximately 200 holes of 0,8 mm diameter.

NOTE An acceptable alternative is a 60 mesh nickel gauze cone from Federal Test Method Standard 791B-321.2 [29].

E.2.2 Beaker, of capacity 50 ml, cut to a height of 41,0 mm.

E.2.3 Gravity convection oven, capable of maintaining 100 °C ± 1,1 °C (212 °F ± 2 °F).

E.2.4 Precision balance.

E.2.5 Desiccator.

E.3 Procedure

Weigh approximately 11 cm³ of sample into the nickel filter cone. Take care to avoid formation of air pockets within the compound. The exposed surface of the compound should be smooth and convex to prevent trapping free oil. Suspend the cone in a tared beaker so that the cone tip is approximately 9,5 mm from the bottom of the beaker. Place the cone-beaker assembly in the oven for 24 h at 100 °C (212 °F) and then weigh. Remove the cone from the beaker; cool the beaker in a desiccator and weigh. Calculate the gain in mass of the beaker as percent oil separation, expressed as percent volume fraction.

To calculate the percent volume fraction, first determine the mass density (kg/m³) of the test compound sample. The mass of the amount required for test is determined either by direct measurement or by subtracting the tare mass of the test equipment containing the sample from the total mass of the sample plus equipment. The volume of the sample in cubic centimetres is then calculated by dividing the sample mass in grams by its mass density and multiplying by 1 000. The oils or volatiles lost by separation or evaporation can be assumed to have an approximate mass density of 900 if they are hydrocarbon based. The volume of the separated/evaporated materials is calculated by dividing the measured mass loss in grams by 900 (or the actual mass density if known to be different) and multiplying by 1 000. The percent volume fraction loss is then calculated by dividing the volume of the separated/evaporated material by the volume of the starting sample and multiplying by 100.

5) Fisher Scientific Company Cat. No. 9-760 or equivalent. The Fisher Scientific Company cone is an example of a suitable product available commercially. This information is given for the convenience of users of this International Standard and does not constitute an endorsement by ISO of this product.

Annex F (normative)

Application/adherence test

F.1 General

This annex describes a method for evaluating the “brushability” and adherence of a thread compound.

F.2 Apparatus

- F.2.1 **Sample can**, capable of holding approximately 450 cm³ of test compound.
- F.2.2 **Paint brush**, with short (3 cm), stiff bristles, of width 3 cm to 5 cm.
- F.2.3 **Pin-end**, cut off from Label 1: 2-7/8 in threaded tubing.
- F.2.4 **Cooling chamber**, capable of maintaining $-7\text{ °C} \pm 1,1\text{ °C}$ ($19\text{ F} \pm 2\text{ °F}$).
- F.2.5 **Gravity convection oven**, capable of maintaining a temperature of $66\text{ °C} \pm 1,1\text{ °C}$ ($151\text{ °F} \pm 2\text{ °F}$).

F.3 Procedure

F.3.1 Cold application and adherence

Place approximately 450 cm³ of thread compound into a suitable sample can (F.2.1). Refrigerate compound sample, brush (F.2.2) and pin-end (F.2.3) to -7 °C ($19\text{ °F} \pm 2\text{ °F}$) (F.2.4) until temperature stabilizes (minimum 2 h).

After thermal stabilization, brush the compound onto the threaded area of the pin-end. Evaluate whether the brushability and adherence are such that the compound can be applied without agglomeration or significant voids in a smooth, uniform layer of approximately 2 mm thickness. Record and report results and observations.

F.3.2 Elevated temperature adherence

Place approximately 450 cm³ of thread compound into a suitable sample can (F.2.1). Weigh and record, to the nearest 0,1 g, the combined total mass of the compound sample, container and application brush (F.2.2). Weigh and record, to the nearest 0,1 g, the mass of the API tubing pin-end (F.2.3).

Brush the compound onto the threaded area of the pin-end in a smooth, uniform layer of approximately 2 mm thickness. Reweigh and record, taking care not to disturb or remove the compound applied to the tubing specimen. Verify by difference that the amount of compound applied to the pin-end is consistent with the amount removed from the container.

Place the coated pin-end, suspended or supported horizontally over a collection tray, in the 66 °C (151 °F) oven (F.2.5) for 12 h to 17 h. Weigh and record to the nearest 0,1 g the mass of the pin-end with remaining adhering compound.

Calculate the mass loss of compound from the tubing pin-end as percent mass fraction. Record and report test results and observations.

Annex G (normative)

Gas evolution test

G.1 General

This annex describes a procedure for measuring the gas evolved from a thread compound at a specified temperature.

G.2 Apparatus

G.2.1 Apparatus, as shown in Figure G.1, Figure G.2 or equivalent.

G.3 Procedure

- a) Fill test vessel to within 15 mm of the top edge with test compound, being careful to avoid air pockets. The use of a vibrator is helpful. Smooth top surface flush.
- b) Seal the test vessel, close needle valve and insert the test vessel assembly into an oil bath preset at the test temperature.
- c) Attach the test vessel assembly by means of tubing to the gas bottle and manometer.
- d) Open the needle valve.
- e) At the end of 15 min, observe the pressure increase indicated by the manometer. This increase is caused ordinarily by the normal expansion of air in the system and of the compound itself.
- f) Open valves and measure displaced water by means of a graduate. Record. Close valves.
- g) Repeat step f) at periodic intervals over a five-day test period.
- h) Calculate evolution of gas as follows: Determine displacement, in cubic centimetres, caused by normal expansion of air and compound at the test temperature. Subtract from total displacement. The remainder is displacement caused by gas evolution.

G.4 Sample test data

a)	Oil bath temperature	66 °C (151 °F)
b)	Room temperature	25 °C (77 °F)
c)	Temperature difference	41 °C (106 °F)
d)	Coefficient of expansion of air (change in volume per unit volume per °C)	0,003 67
e)	Diameter of container ($D = 2r$)	50,0 mm
f)	Air depth (h)	15,0 mm

G.5 Calculations

- a) Volume, V , of air in test vessel above compound at 25 °C (77 °F):

$$\begin{aligned} V &= \pi r^2 h = 3,141\ 6 \times (2,50\ \text{cm})^2 \times 1,50\ \text{cm} \\ &= 29,45\ \text{cm}^3 \text{ (initial air volume)} \end{aligned}$$

- b) Expansion of the volume of air in test vessel at 66 °C (151 °F):

$$\begin{aligned} V_2 &= 29,45 \times 0,003\ 67 \times 41 \\ &= 4,43\ \text{cm}^3 \text{ (expansion of the volume of air in test vessel is the volume of air displaced)} \\ 4,43/29,45 \times 100 &= 15,04\ \% \text{ (volume change)} \end{aligned}$$

- c) Contraction of initial air volume displaced from test vessel due to cooling to 25 °C (77 °F):

$$4,43 \times 15,04\ \% = 0,67\ \text{cm}^3$$

- d) Corrected expansion of air displaced from the test vessel:

$$4,43 - 0,67 = 3,76\ \text{cm}^3$$

- e) Evolved gas = total displaced volume minus corrected displaced air expansion volume.

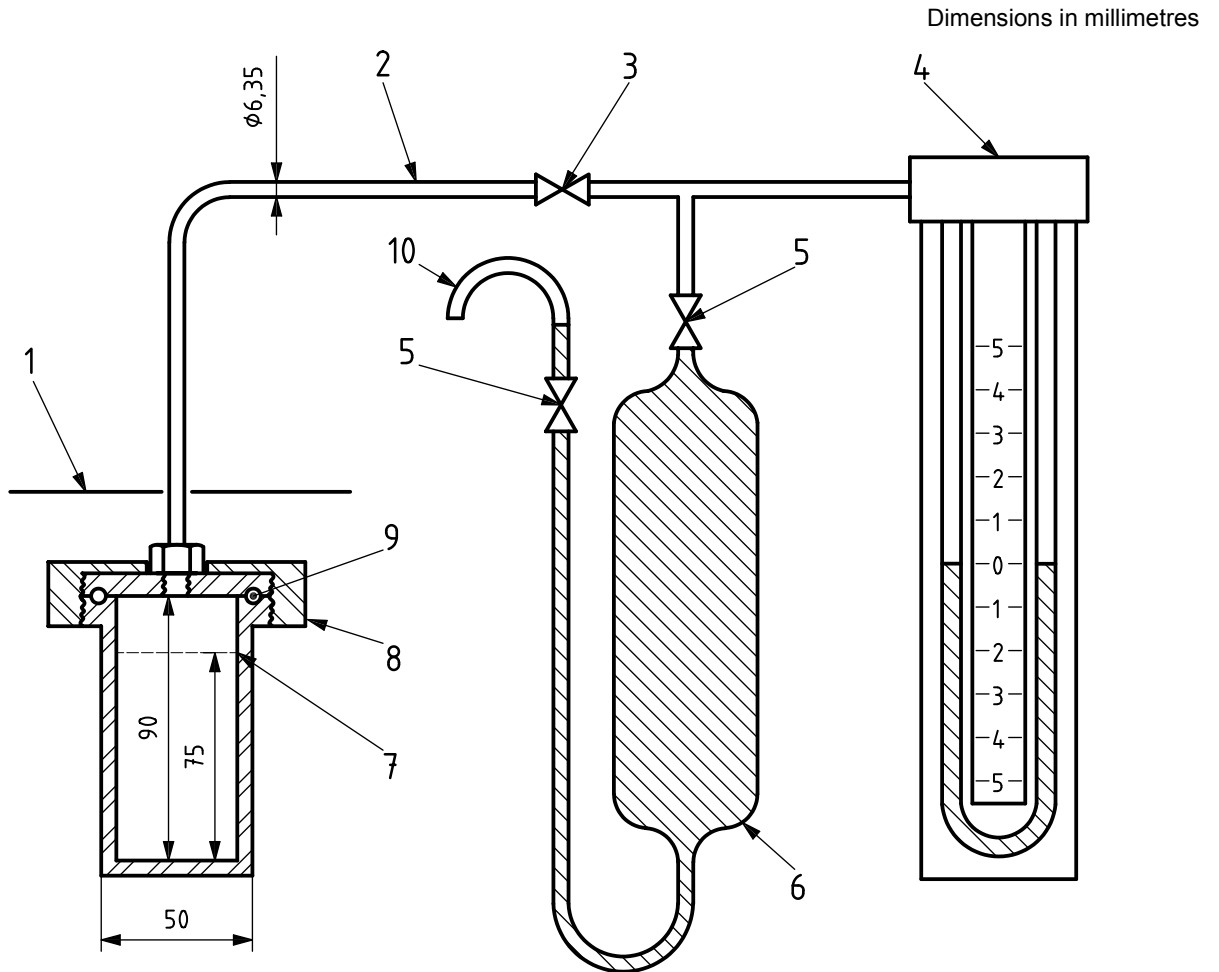

Key

- | | |
|---------------------------|--|
| 1 oil bath level | 6 250 cm ³ gas bottle, water-filled |
| 2 stainless steel tubing | 7 compound sample level |
| 3 valve | 8 test vessel |
| 4 25 cm mercury manometer | 9 silicone rubber O-ring |
| 5 valves | 10 line to measure displaced volume |

Figure G.1 — Example 1 of gas evolution test apparatus

Dimensions in millimetres

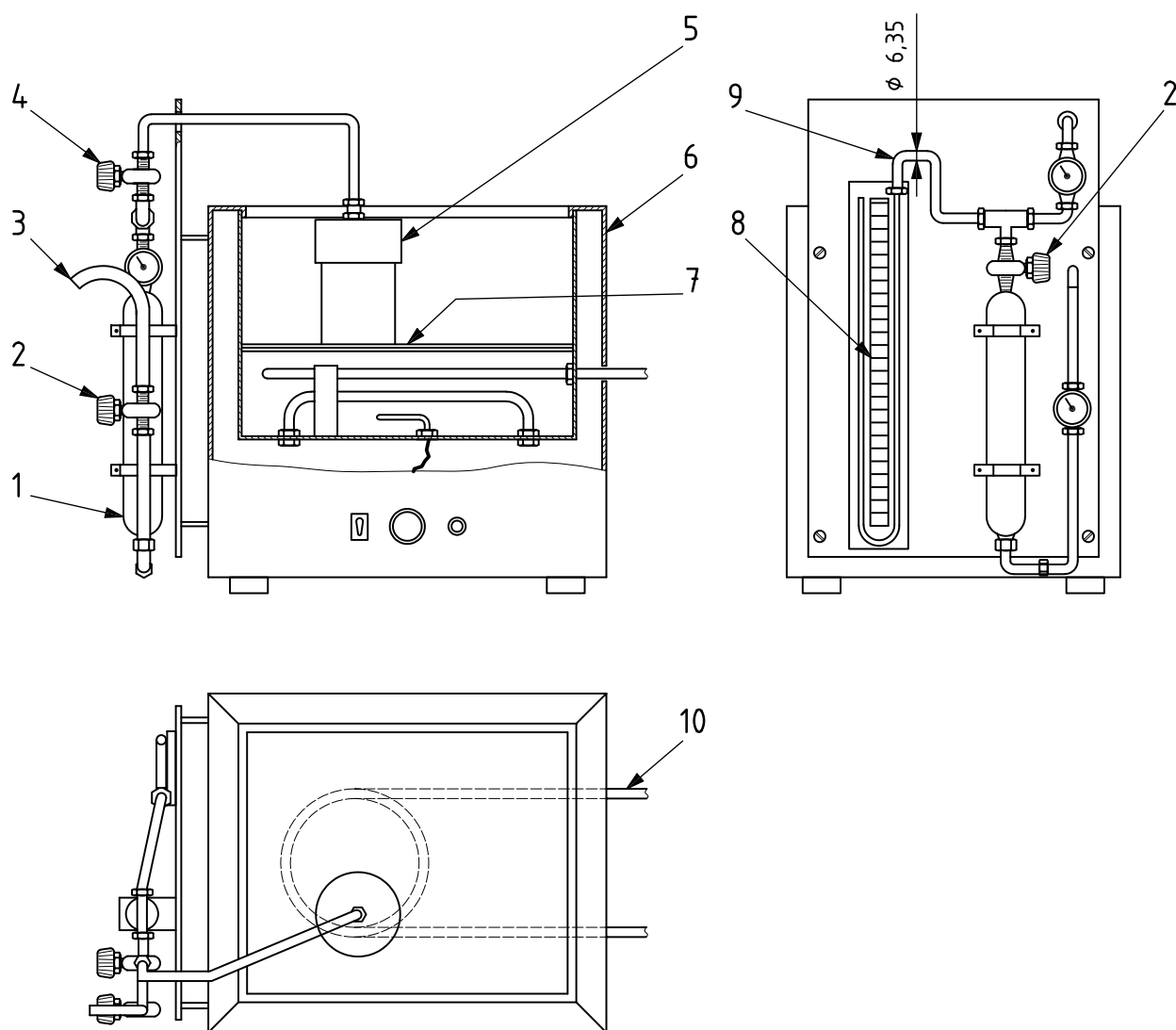

Key

- | | | | |
|---|--|----|---|
| 1 | 250 cm ³ gas bottle, water-filled | 6 | constant-temperature bath |
| 2 | valves | 7 | shelf |
| 3 | line to measure displaced volume | 8 | 25 cm mercury manometer |
| 4 | valve | 9 | stainless steel tubing |
| 5 | test vessel | 10 | 66 °C water supply (see footnote a in Figure H.2) |

Figure G.2 — Example 2 of gas evolution test apparatus

Annex H (normative)

Water leaching test

H.1 General

This annex describes a procedure for determining the ability of thread compound to resist the washing action of water.

H.2 Apparatus

As shown in Figure H.1, Figure H.2 or equivalent, including the following.

- H.2.1 Filter cone**, Coors No. 3, porcelain, 50 mm in diameter.
- H.2.2 Glass beaker**, of capacity 100 ml with six equally spaced 6 mm holes located 1,6 mm from the bottom.
- H.2.3 Triangle**, chrome, to support the cone.
- H.2.4 Beaker**, of capacity 100 ml.
- H.2.5 Beaker**, of capacity 1 000 ml, with side-arm extension at the bottom.
- H.2.6 Copper screen**, 1,6 mm mesh.
- H.2.7 Brass cylinder**, of length 150 mm with a diameter of 75 mm, wall thickness approximately 6 mm, overflow 20 mm from the top, 3,0 mm orifice centred in the bottom.
- H.2.8 Centrifugal pump**, capable of circulating 1 litre of 66 °C (151 °F) water per minute.
- H.2.9 Connecting hose**, two pieces, of 6,35 mm ID.
- H.2.10 Ring stand**.
- H.2.11 Heater**.

H.3 Procedure

Fill a tared porcelain filter cone (H.2.1) with approximately 17 g of sample, smooth the top and make a slight concavity of about 1 mm with a spatula. Suspend the cone in the 100 ml beaker (H.2.4) and support both on a triangle (H.2.3) in the 1 000 ml beaker (H.2.5). Place the entire glass assembly on the hot plate which is elevated from the pump (H.2.8). Support the brass cylinder (H.2.7) by a clamp from the ring stand (H.2.10). Place the mesh screen baffle equidistant between the brass cylinder and the upper rim of the cone, which are located 13 mm apart. Recycle from the 1 000 ml beaker to the brass cylinder at least 500 ml of distilled water, previously heated to 66 °C (151 °F) in the 1 000 ml beaker and regulate by a screw clamp so that the head of the water is just up to the overflow level. Any water washed through the grease escapes via the holes in the small beaker into the large beaker, where it has been noted that it clings to the side.

Recirculate the water for 2 h during which time the temperature remains between 60 °C and 66 °C (140 °F and 151 °F).

After the test has been completed, disassemble the apparatus, dry the cone and contents for a period of 24 h at 66 °C (151 °F) and calculate the mass loss as a percent mass fraction.

Dimensions in millimetres

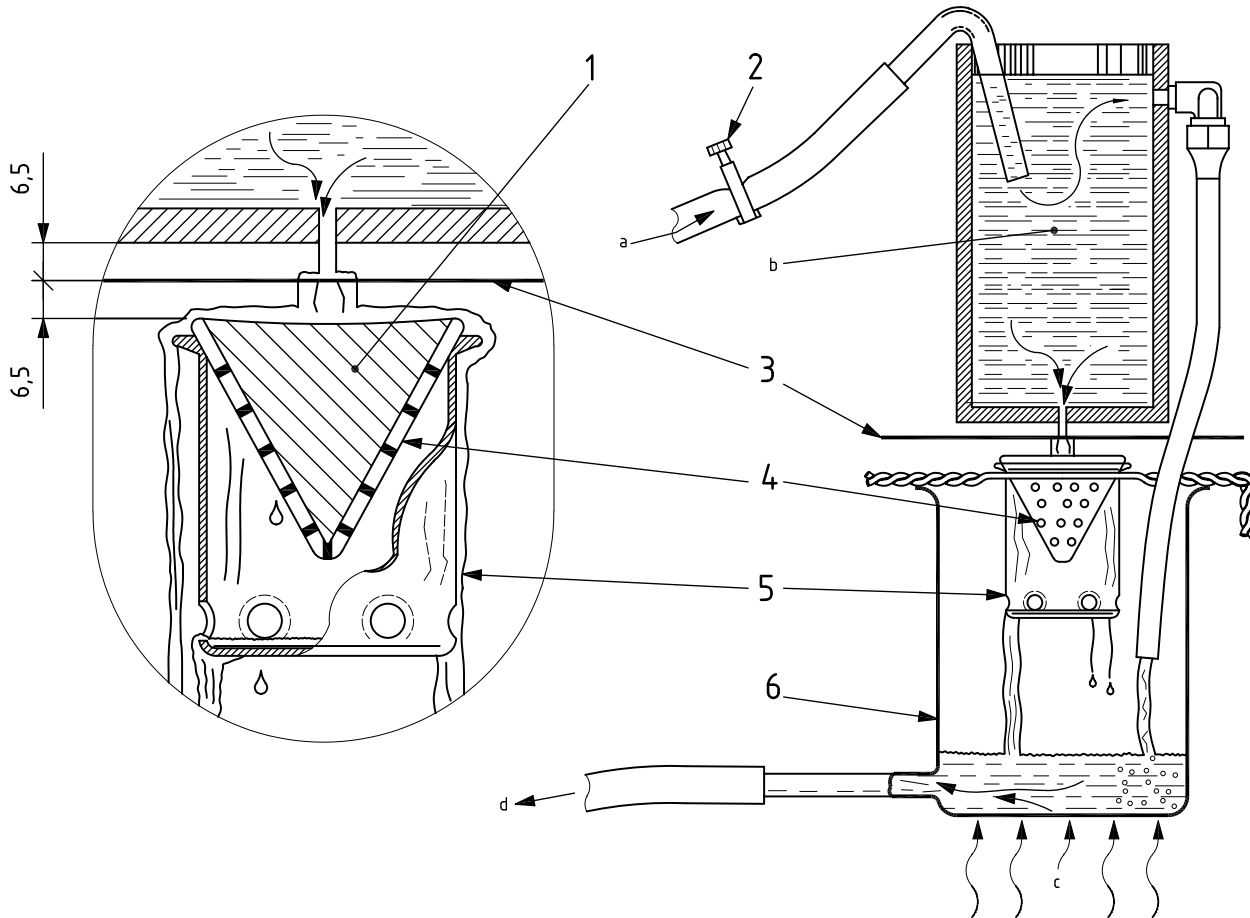

Key

- 1 compound sample
- 2 flow-regulating valve
- 3 copper screen, 1,6 mm mesh
- 4 porcelain cone
- 5 100 ml beaker, modified
- 6 1 000 ml beaker, modified

- a Flow from the pump.
- b Water supply under uniform pressure head.
- c Applied heat.
- d Flow to the pump.

Figure H.1 — Example 1 of water leaching test apparatus

Dimensions in millimetres

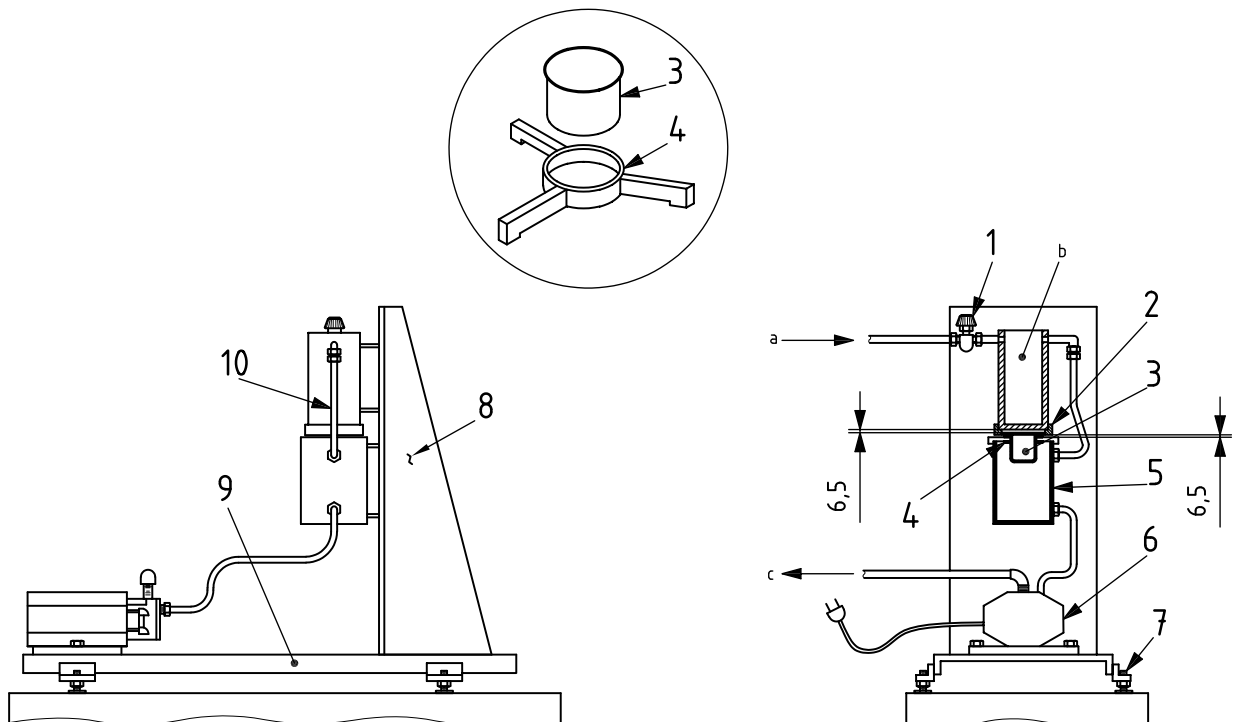

Key

- | | | | |
|---|---------------------------------|----|------------------|
| 1 | flow-regulating valve | 6 | pump |
| 2 | threaded ring and copper screen | 7 | levellers |
| 3 | compound sample cup (see inset) | 8 | vertical support |
| 4 | holder (see inset) | 9 | support platform |
| 5 | receiver cylinder | 10 | overflow tube |

NOTE Constant-temperature bath located in gas-evolution test apparatus (see Figure G.2)

- a Flow from constant-temperature bath (see Figure G.2).
- b Water supply under uniform pressure head.
- c Flow to constant-temperature bath.

Figure H.2 — Example 2 of water leaching test apparatus

Annex I (informative)

Frictional properties test

I.1 General

The thread compound manufacturer is responsible for defining frictional performance of the thread compound.

I.2 Industry test methods

The API has carried out investigations of pipe thread compounds [8]. Clause 4 "Small-scale friction test development" provides a history of development of test methods for thread compound frictional properties. Section 6 describes the procedure for a full-scale connection test which includes the evaluation of compound frictional properties for API-type connections. ISO 13679 describes test procedures for any threaded connection.

I.3 Full-scale test for casing, tubing and line pipe

At least two test protocols utilizing multiple-connection test samples should be performed; one for tubing, preferably Label 1: 3 ½ in and one for casing, preferably Label 1: 9 5/8 in. Since the apparent coefficient of friction of the thread compound/connection system can vary with thread form, seal variation and material grade and finish, care should be exercised to ensure uniformity of connection test sample variables.

NOTE The full-scale API test procedure referenced in these sections specifies a certain number of turns past a low "reference torque" for the make-up of 8-round test specimens. Full-scale test data from a combined API/Joint industry research project (API 1997 [7]) demonstrated that if thread compounds have substantially different friction properties and/or compositions (e.g. solid component type or particle size, volume percent solids), there can be a significant difference (one full turn or greater) in the initial engaged position or stand-off to the test specimen connection members when using a standard reference torque. This difference in the initial stand-off results in a similar difference in the final engaged position. It is essential that any comparative testing of thread compounds, either for frictional properties or fluid sealing properties, be done to the same final engaged position within the allowable API tolerances. This is because the amount of engagement of the connection members determines both the pull-out strength and the leaktightness of the connection. In the research project referenced above, an initial reference stand-off was established using the reference standard. The connection test specimen for all subsequent compounds tested was initially made-up to the reference stand-off, the torque recorded and then made-up to the specified number of turns to the final engaged position.

For more information, including a comparison of the performance of the reference standard to a commercial formulation of API modified thread compound, the summary report of the referenced research project can be reviewed.

I.4 Small-scale test

I.4.1 General

This small-scale test procedure, formerly API RP 7A1 [6] was developed and validated utilizing the metal-based RSC compounds that were commonly used in field applications in the early 1990s. Subsequent industry test programmes utilizing non-metallic RSC compounds have shown limited correlation of small-scale test frictional properties with full-scale test results.

The coefficient of friction of typical tubing and casing compounds determined using API RP 7A1 [6] ranges from 0,067 to 0,08. However, when full-scale tests are performed on API 8-round connections, the same

compounds can indicate frictional coefficients as low as 0,02 to 0,04. This difference might possibly be caused by reduced surface contact pressure between the full-scale connection members as they "float" together on a thick layer of thread compound, as well as the significant difference in the connection variables described above. Thus, an apparent coefficient of friction is indicated. A test method should be selected to take into account such variables, including volume of compound applied.

An example of a small-scale test is the procedure described in API RP 7A1 [6]. This procedure utilizes a shouldered fixture with cylindrical threads. It does not entrap the thread compound, allowing the film thickness to be very thin. The surface contact pressure is relatively high, between 200 MPa (29 000 psi) and 425 MPa (65 250 psi). This compares to 35 MPa (5 075 psi) to 140 MPa (20 300 psi) for API casing, tubing and line pipe connections.

I.4.2 Procedure

I.4.2.1 The purpose

This subclause defines

- a) the procedure for determining the friction factor of rotary shouldered connection thread compounds,
- b) the calculation procedure for rotary shouldered connection make-up torque, and
- c) the recommended marking of the thread compound containers.

This subclause outlines a procedure for determining thread compound frictional performance, describes the statistical analysis method for evaluating the test results and shows how to use the results of the tests. Using the results from this test does not guarantee failure-free rotary shouldered connection service in the field. This information is to assist the user in selecting the most appropriate make-up torque for the thread compound in use.

I.4.2.2 Summary of the test procedure

The relative frictional performance of a thread compound is determined by using a threaded, shouldered bolt-type specimen and recording torque versus turns data as shown in Figure I.1. One cycle is defined as a single make and break of the specimen. A minimum of eight cycles should constitute one test run for either the reference compound or the test compound. A complete test consists of three test runs as follows:

- a) a calibration run performed using the rotary shouldered connection (RSC) reference standard formulation;
- b) a run performed using the test compound;
- c) a repeat run using the RSC reference standard formulation.

The friction factor for a thread compound is determined by dividing twice the test compound results into the sum of the two results from the RSC reference standard formulation. Other properties of thread compounds such as galling prevention and resistance to down hole make-up are outside the scope of this test procedure.

I.4.2.3 The RSC reference standard formulation

This test method utilizes a reference formulation to simultaneously calibrate the specimen, the loading machine and the instrumentation. It is a simple mixture of common components that can be readily mixed and can yield consistent results when tested in the manner described in the following sections. This reference formulation is not intended for use as a thread compound and is only a laboratory calibration material.

ISO 13678:2009(E)

The RSC reference standard formulation is:

Component	Percent by mass
Lead powder	60,0 ± 1,0
Grease base	40,0 ± 1,0
Total	100,0

Lead powder shall conform to the following requirements:

Free metal content, % minimum	95
(ASTM D1301 [17])	
Lead oxide content, % maximum	5
(ASTM D1301 [17])	

Particle size:

Pass No. 50 sieve, % minimum	100
On No. 100 sieve, % maximum	1
On No. 200 sieve, % minimum	5
% maximum	25
Pass No. 325 sieve, % minimum	40
% maximum	80

(sieve designation as per ASTM E11 [23])

The grease base should conform to the following requirements:

Consistency:

Worked penetration (60 strokes)	265–295
(ASTM D217)	

Thickener:

Lithium 12-hydroxystearate

Percent by mass, % minimum	7
% maximum	9

(ASTM D128 [12])

Base oil:

Petroleum/Non-synthetic

Viscosity	at 40 °C	115 cSt minimum
		170 cSt maximum
	at 100 °C	9,5 cSt minimum
		14,0 cSt maximum

(ASTM D445 [14])

The grease base shall contain no additives such as extreme pressure, anti-wear, or any other additive that could affect the frictional properties of the RSC reference compound.

WARNING — Lead has been determined to be toxic. Mark, store, report and dispose of RSC reference standard formulation in accordance with federal, state and local regulations.

I.4.2.4 Test specimen

The test specimen is shown in Figure I.2. The threads are 1-8 UNC and should conform to ASME B1.1 [9] with a 2A and a 2B fit. The material of the specimen should be AISI 4130 steel bar (UNS G41300) quenched and tempered to a Brinell hardness range of 285 to 341 through the complete cross-section. The shoulder and the thread of each component should be single-point cut without removing the part from the chuck to ensure that the shoulder is perpendicular to the axis of the threads. The surface finish on mating surfaces should be $0,8 \pm 0,4 \mu\text{m Ra}$ ($32 \pm 16 \mu\text{in RMS}$). There should be no surface treatment on the machined surfaces of the test specimen.

I.4.2.5 Test apparatus

The thread compound should be tested in a machine capable of applying an increasing torque at a uniform rate to the specimen while recording the torque and rotation. The torque on the specimen should be between 271 N·m and 407 N·m (200 ft·lb and 300 ft·lb) when the friction data is taken. The data acquisition instrumentation may be either analogue or digital. Care must be taken to ensure that the frequency response of either type of system is adequate to acquire representative data.

An example of a mechanical system is shown in Figure I.3. The test machine consists of three sections. The first section of the machine is the motor/gearbox that supplies the rotation and torque to the specimen. The rotational frequency should be $1 \text{ r/min} \pm 10 \%$. The torque capability of the machine should be at least 475 N·m (350 ft·lb) and should be reversible. The second section of the machine is the torque transducer, which resists rotation of the specimen and produces an output signal that is proportional to the applied torque. This transducer should have a maximum capability between 542 N·m and 1 085 N·m (400 ft·lb and 800 ft·lb). The third section of the machine is the rotation transducer that produces an output signal that is proportional to the angle through which the specimen is rotated.

The signal for the rotation and torque transducers should be recorded in such a way that there is a one-to-one correspondence between data points for torque and data points for rotation.

I.4.2.6 Test conditions

This test should be conducted with the apparatus, the reference compound and the test compound at a temperature between 15,6 °C and 37,8 °C (60 °F and 100 °F). The relative humidity should be between 20 % and 95 % and non-condensing. The apparatus, environment and the test compounds are not required to be simultaneously at the same temperature, but rather within the prescribed range. Results of tests performed at conditions outside of those listed above should be so noted.

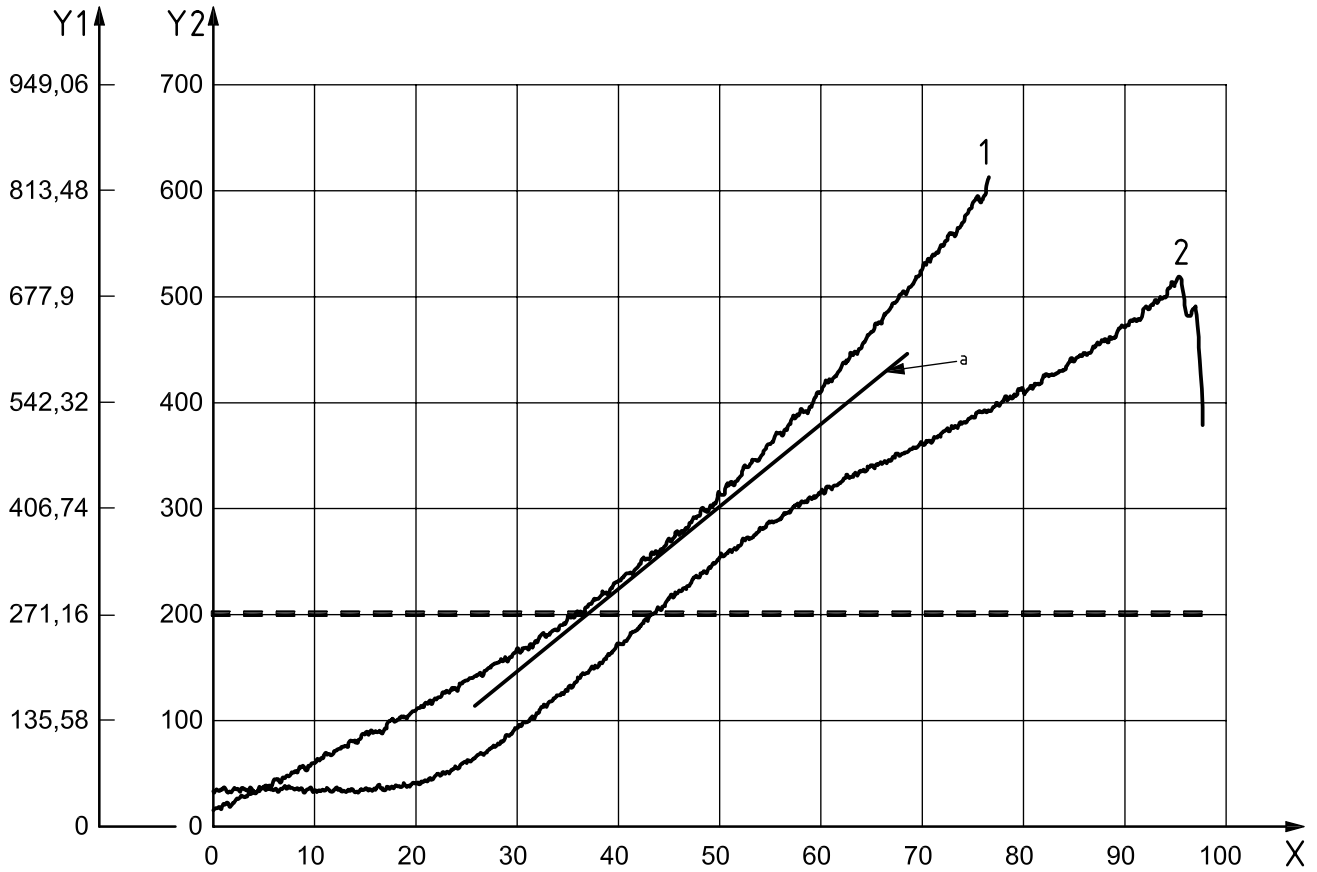

Key

- X rotation, expressed in degrees
- Y_1 torque, expressed in Newton metres^b
- Y_2 torque, expressed in foot-pounds^b
- 1 make-up
- 2 breakout
- a Straight line: least squares fit of slope of torque vs. rotation over the torque range of 270 N-m to 408 N-m (200 ft-lb to 300 ft-lb).
- b Torque range 270 N-m to 408 N-m (200 ft-lb to 300 ft-lb).

Figure I.1 — Plot of typical torque vs. turn data

Dimensions in millimetres
(Dimensions in inches)

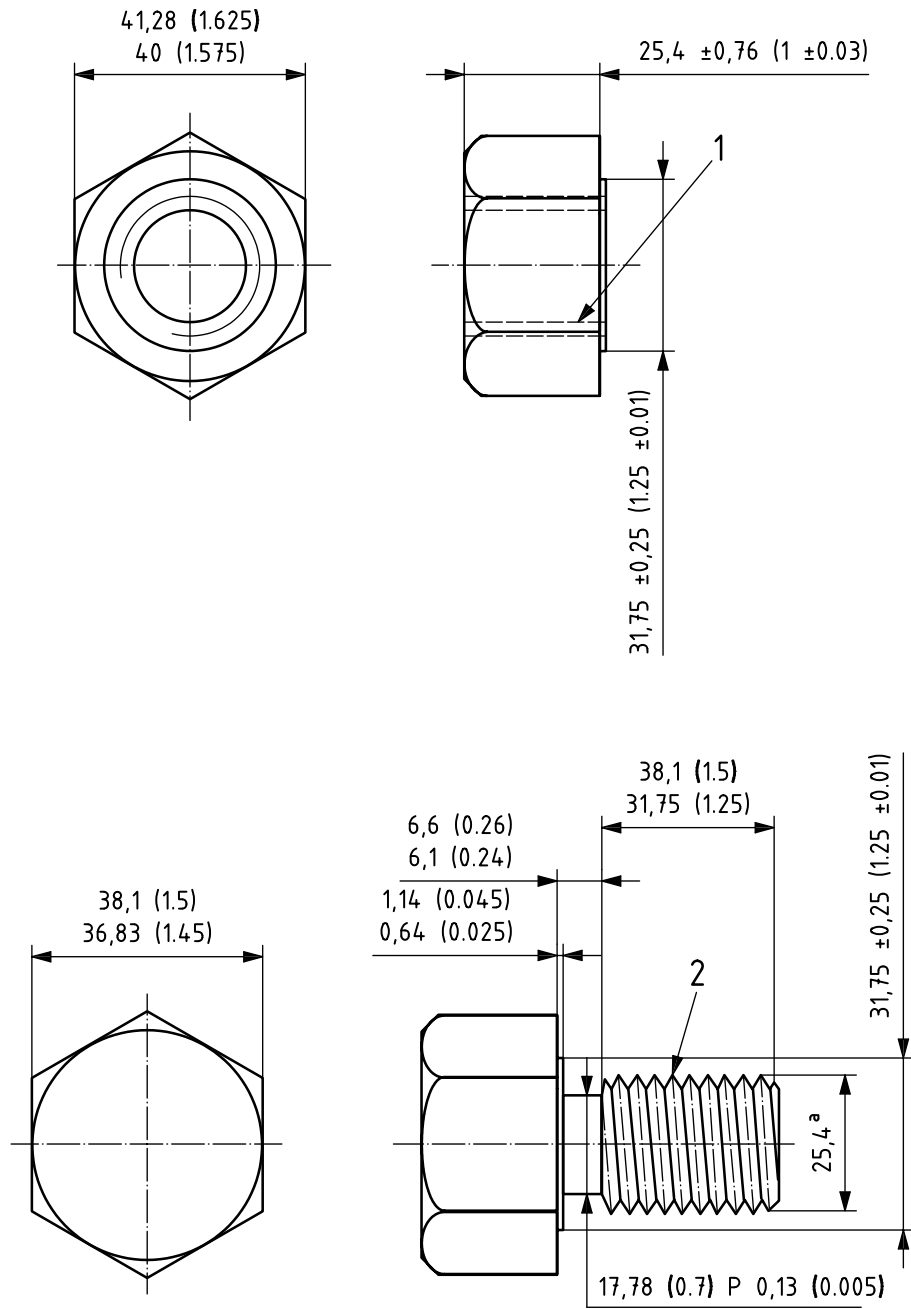

Key

- 1 1-8 UNC 2B threads per ASME B1.1 [9]
- 2 1-8 UNC 2A threads per ASME B1.1 [9]
- a 1 000 ref.

Figure I.2 — Test specimen

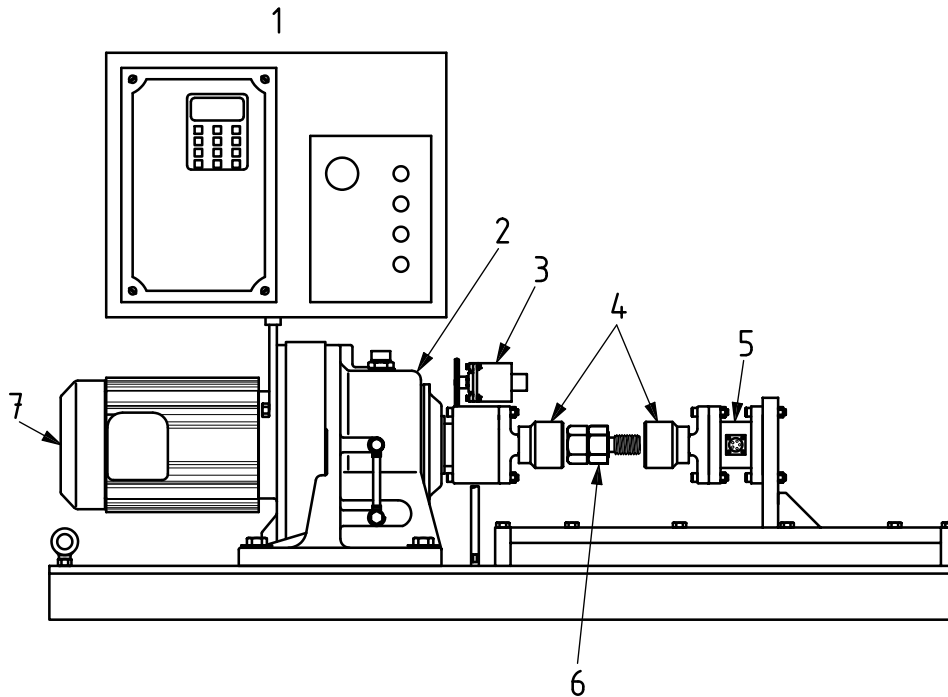

Key

- 1 control panel
- 2 gear box
- 3 rotation transducer
- 4 hex sockets
- 5 torque transducer
- 6 test specimen
- 7 motor

Figure I.3 — Thread compound test machine

I.4.3 Thread compound test procedure

I.4.3.1 New specimen break-in

Each newly manufactured specimen should be subjected to 20 make-and-break cycles using the reference compound before actual tests are performed. The specimen should then be cleaned using the recommended procedure.

I.4.3.2 Specimen cleaning

The specimen should be cleaned with any appropriate solvent, wire brushed to remove any plated soft metal and degreased. The specimen should then be dried before applying the next test compound.

CAUTION — Solvents and degreasers can contain hazardous materials. Material Safety Data Sheets should be available, read and the precautions observed when handling products of this type.

I.4.3.3 Sample submission and storage

The sample of the compound to be tested should be submitted in a clean, leak-proof container that can be sealed to prevent evaporation of any volatile materials or the possible contamination of the compound. The sample volume should be approximately 250 ml (8 fl oz). The sample should be stored within the temperature range of 15,6 °C to 37,8 °C (60 °F to 100 °F). If the sample is submitted in a container of approximately 4 litres

(1 gallon), a convenient portion for storage and testing can be transferred to a smaller container that meets the above requirements. It is extremely important that, before the transfer of the sample to an alternate container, or prior to the actual test procedure, the sample is stirred to ensure homogeneity. Care should be taken when stirring the sample that material is not scraped or abraded from the container itself that could contaminate the sample and affect test results.

I.4.3.4 Torque test

All mating surfaces of the test specimen should be coated with a liberal layer of the thread compound. The specimen should then be made up hand-tight and placed in the testing machine. The initial or hand-tight torque should not exceed approximately 14 N·m (10 ft·lb). The torque and the rotation should then be recorded as the torque is increased to 420 ± 14 N·m (310 ± 10 ft·lb). After these data are recorded, the specimen should be loosened by applying a torque in the opposite direction. The specimen should then be removed from the testing machine. The two parts of the specimen should be unscrewed sufficiently to expose all but two or three threads and more thread compound should be reapplied to the mating surfaces. The specimen should then be made up hand-tight and replaced in the test machine. The next set of data should then be taken. This procedure should be repeated for a minimum of 8 cycles to a maximum of 10 cycles. A minimum of 8 cycles should constitute one run and be used for the calculations in I.4.3.6. If more than 8 cycles are performed, the operator can choose to reject any cycle of the 9 or 10 cycles performed.

I.4.3.5 Test specimen inspection

After a run has been completed, the specimen should be cleaned as described in I.4.3.2. If there are any signs of galling of the mating surfaces, the compound is rejected and the test is complete. The diameter of the cylindrical section of the specimen should be determined to within 0,025 mm (0.001 in) gauging accuracy and recorded before and after each compound test so that yielding of the specimen is detected. This measurement should be taken each time the specimen is cleaned. If the diameter change exceeds 0,127 mm (0.005 in), the test is invalid.

I.4.3.6 Data reduction

For each individual torque versus rotation test on any compound, the result of that test is the slope, m , of the least squares fit of a straight line to the torque versus rotation data over the range of torque from 271 N·m to 407 N·m (200 ft·lb to 300 ft·lb). At least 20 pairs of data points should be used for this analysis.

The resulting slopes, m , from the 8 to 10 cycles specified in I.4.3.4 should be statistically analysed to determine the average slope and standard deviation, σ , of 8 cycles, as given in Equations (I.1) to (I.3).

$$m = \frac{\sum(A - \bar{A})(T - \bar{T})}{\sum(A - \bar{A})^2} \quad (\text{I.1})$$

$$s = \frac{\sum(m)}{N} \quad (\text{I.2})$$

$$\sigma = \sqrt{\frac{N \times \sum(m^2) - [\sum(m)]^2}{N \times (N - 1)}} \quad (\text{I.3})$$

where:

A is the measured angle data point;

\bar{A} is the average of angles at which data was collected;

m is the slope;

ISO 13678:2009(E)

N is 8;

s is the average slope;

T is the measured torque data point;

\bar{T} is the average of torque values collected.

I.4.3.7 Friction factor

The friction factor for the compound is given in Equation (I.4):

$$FF = \frac{2 \times S_2}{S_1 + S_3} \quad (I.4)$$

where

S_1 is the average slope for first reference compound runs;

S_2 is the average slope for test compound runs;

S_3 is the average slope for second reference compound runs.

I.4.4 Application of friction factor

Recommended make-up torque for rotary shouldered connections were calculated using a coefficient of friction of 0,08 and are tabulated in API RP 7G. A thread compound with a friction factor other than 1,0 does not have a coefficient of friction of 0,08 and uncorrected tabulated torque values can result in improperly made-up connections.

The thread compound friction factor is used to correct the make-up torque for drill stem elements.

Thread compound performance is based on this test procedure and not a specific friction factor. Drilling conditions exist where a friction factor of greater or less than 1,0 is beneficial.

The make-up torque can be corrected by multiplying the make-up torque value found in API RP 7G by the friction factor of the compound.

EXAMPLE:

Drill pipe assembly – Label 1: 5", 19.50, G-105 premium with 5 1/2 × 3 1/4 NC50 tool joints

Make-up torque from API RP 7G – 29 715 N·m (21 914 ft·lb)

Thread compound friction factor – 0,9

Corrected make-up torque

$$29\,715 \times 0,9 = 26\,744 \text{ N·m (19 723 ft·lb)}$$

I.4.5 Test certification and marking

I.4.5.1 Test certification

Thread compound manufacturers wishing to comply with this International Standard should display the frictional performance data of their compound according to the guidelines in I.4.3. The thread compound manufacturer should provide, upon request, certified copies of the test results that were obtained using the

methods and equipment described in this practice. The results should include the manufacturer's name, product name, date of testing and the name of the testing laboratory.

I.4.5.2 Marking

Thread compounds which have been tested in accordance with this International Standard may be so labelled. The label should contain the following markings:

- a) a reference to this International Standard, i.e. ISO 13678:2009;
- b) the friction factor, i.e. "friction factor = X,X" or "FF (ISO 13678) = X,X", comprising no more or less than two digits with one digit to the right of the decimal sign.

NOTE Drilling conditions exist where a friction factor other than 1,0 is acceptable and/or desirable, therefore product conformance is based on the test methods described in this recommended practice and not on a specific value of the friction factor.

Annex J (informative)

Extreme surface-contact pressure (galling) test for casing, tubing and line pipe

J.1 General

The thread compound manufacturer is responsible for determining the extreme surface-contact pressure performance of the thread compound. Since industry consensus has not been achieved, manufacturers and users are encouraged to further develop galling test methods until such acceptance occurs.

J.2 Industry test methods

Currently, the only reliable test methods are full-scale connection tests (repeated make-and-break of connection assemblies) such as described in ISO 13679 or API RP 5C5. These provide information on test methods for thread compound extreme surface-contact pressure (galling) properties and a full-scale connection test procedure, which includes the evaluation of compound galling-resistance properties for API-type connections.

Annex K (informative)

Fluid sealing test for casing, tubing and line pipe

K.1 General

The thread compound manufacturer is responsible for defining the sealing performance of the thread compound. Since industry consensus has not been achieved, manufacturers and users are encouraged to further develop sealing test methods until such acceptance occurs. Minimum required test parameters are given in Clause K.3.

K.2 Industry test methods

Currently, the only reliable method to obtain the required information is to conduct full-scale connection tests on the specific thread compound/connection system, such as described in ISO 13679 or API RP 5C5. These describe full-scale connection tests for the evaluation of thread compound fluid sealing properties. Numerous attempts have been made to design laboratory tests for evaluating the sealing ability of tubing and casing thread compounds for API-type connections. At least 11 attempts have been made between 1957 and 1993 to develop a small-scale test for thread compound sealing ability. Of these 11 different methods, none has achieved industry acceptance or been adopted by either thread compound manufacturers or users. From these past efforts, it is clear that designing a small-scale test to determine the sealing ability of thread compounds is difficult.

The most recent effort by API utilized a spiral groove that closely approximated API buttress thread clearances. Some inconsistency was found and can be attributed as much to particle size variation among compounds as to the test method itself. Further evaluation of this method could indicate a positive capability to discriminate between compounds. However, the influence of particle shear properties on sealing has not been accounted for by this method.

NOTE The full-scale test procedure referenced in these clauses specifies a certain number of turns past a low "reference torque" for the make-up of 8-round test specimens. Full-scale test data from a combined API/Joint industry research project (API 1997^[7]) demonstrated that if thread compounds have substantially different friction properties and/or compositions (e.g. solid component type or particle size, volume percent solids), there can be a significant difference (one full turn or greater) in the initial engaged position or stand-off to the test specimen connection members when using a standard reference torque. This difference in the initial stand-off results in a similar difference in the final engaged position. It is essential that any comparative testing of thread compounds, either for frictional properties or fluid sealing properties, be done to the same final engaged position within the allowable API tolerances. This is because the amount of engagement of the connection members determines both the pull-out strength and the leaktightness of the connection. In the research project referenced above, an initial reference stand-off was established using the reference standard. The connection test specimen for all subsequent compounds tested was initially made up to the reference stand-off and then made up to the specified number of turns to the final engaged position.

For more information, including a comparison of the performance of the reference standard to a commercial formulation of API modified compound, the summary report of the referenced research project can be reviewed.

K.3 Test parameters

The test selected to satisfy the requirements of this International Standard should include the following procedures, at a minimum.

- a) Apply test pressure with dry nitrogen gas. The test pipe specimen should be capable of safely sustaining 70 MPa (10 150 psi) maximum test pressure during the hold period, a minimum of 8 h.
- b) Carry out leak detection by the “bubble” method in accordance with ISO 13679 or API RP 5C5. The leak rate can be monitored by visual recording of observed off-gas over time, or by similar means, to yield a rate measured in cubic centimetres per minute.
- c) Apply pressure as in Figure K.1, starting at 7,0 MPa (1 015 psi), in increments of 7,0 MPa (1 015 psi) with each increment held for a minimum of 15 min. The maximum test pressure should be 70 MPa (10 150 psi) or as agreed between the purchaser and the manufacturer. The maximum pressure (which should be observed continuously for the initial 15 min) should be held for a minimum of 8 h.
- d) Maintain a test log as shown in Figure K.2 and record a continuous strip chart of the test pressure over the complete duration of the test.
- e) Perform reference pressure tests using the reference compound (Annex B), prior to qualifying thread compound tests for record.
- f) Report test results, including both the log and strip chart as part of the test report.

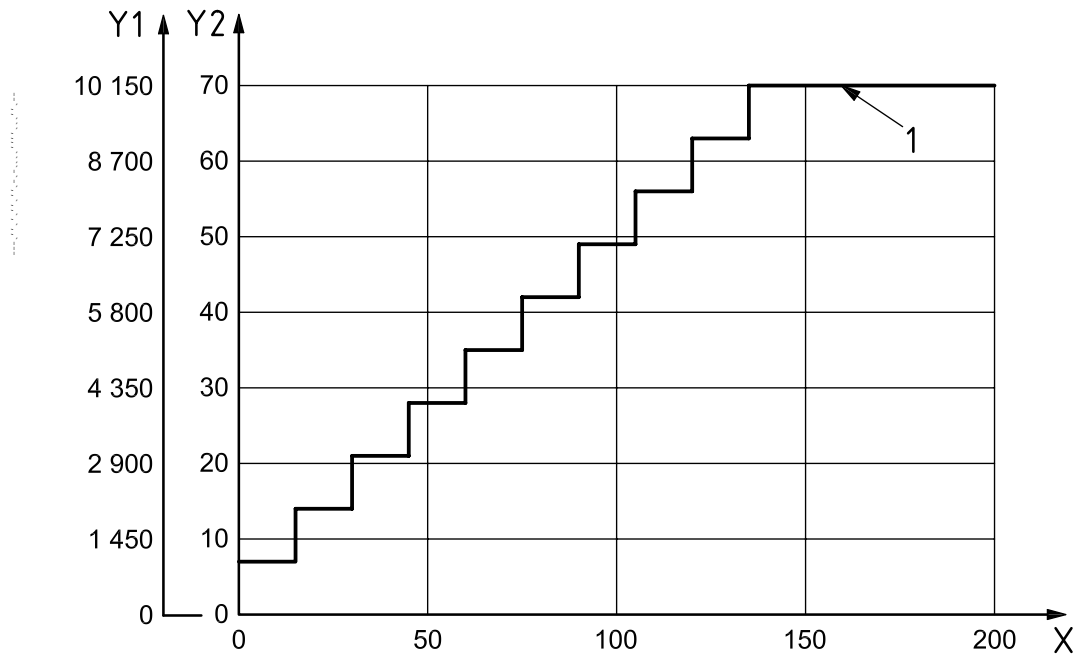

Key

- X hold time, expressed in minutes
- Y₁ pressure, expressed in pound-force per square inch
- Y₂ pressure, expressed in megapascals
- 1 8-h hold at maximum pressure

Figure K.1 — Procedure for thread compound sealability test

Annex L (informative)

Corrosion inhibition tests

L.1 Recommended performance criteria

Thread compounds should provide corrosion inhibition for ISO 11960 [3] or API SPEC 5CT grade L80 material (or similar) for 500 h minimum at 38 °C (100 °F) when tested in accordance with ASTM B117 [10] Salt spray (Fog) test (5 % NaCl, pH neutral), with a collection rate of 1,0 ml/h to 2,0 ml/h per 80 cm². The compound coating should be applied to a uniform thickness of 0,4 mm. Care should be taken to avoid any score marks or other surface striations during sample application. The measured corrosion level should not exceed 1,0 % of the surface area, excluding corrosion due to “edge effects” or corrosion “bleed”.

NOTE A thicker coating and subsequently longer exposure time can be required to evaluate compounds that contain component particle sizes greater than 0,4 mm.

L.2 Alternative tests methods

Alternatively, thread compounds may be evaluated by other test methods, including the following (test duration in parentheses where known):

- a) ASTM D1743 [18] (48 h);
- b) DIN 51802 [25] (164 h);
- c) SPE 11396 [28] (40 days);
- d) NACE 134 [26] (40 days);
- e) NF X 41-002 [27];
- f) ISO 11007 [2].

Annex M (informative)

Compound high-temperature stability test

M.1 General

This annex describes a method for evaluating the high-temperature stability of a thread compound.

M.2 Apparatus

M.2.1 Penetration sample cup, in accordance with ISO 2137 or ASTM D217 or similar (inner dimensions: 7,6 cm diameter × 6,4 cm height).

M.2.2 Oven, gravity convection, capable of maintaining a temperature of $138\text{ °C} \pm 1,1\text{ °C}$ ($280\text{ °F} \pm 2\text{ °F}$).

M.3 Procedure

- a) Place a representative sample of the thread compound into a tared sample container to a level approximately 2 cm below the rim, taking care to exclude any voids.
- b) Reweigh the filled container and calculate the actual volume of the sample, based on the determined mass density (kg/m^3) of the thread compound.
- c) Bake the sample in the gravity convection oven (M.2.2) at $138\text{ °C} \pm 1,1\text{ °C}$ ($280\text{ °F} \pm 2\text{ °F}$) for a minimum of 24 h.
- d) After baking, cool the sample to room temperature and decant any oil that has separated.
- e) Reweigh the sample and record the total loss as a percent volume fraction.
- f) The percent volume fraction is calculated by first determining the mass density (kg/m^3) of the test compound sample. The mass of the amount required for the test is determined either by direct measurement or by subtracting the tare mass of the test equipment containing the sample from the total mass of the sample plus equipment. The volume of the sample in cubic centimetres is then calculated by dividing the sample mass in grams by its mass density and multiplying by 1 000. The oils or volatiles lost by separation or evaporation can be assumed to have an approximate mass density of 900 kg/m^3 if they are hydrocarbon based. The volume of the separated/evaporated materials is calculated by dividing the measured mass loss in grams by 900 kg/m^3 (or the actual mass density if known to be different) and multiplying by 1 000. The percent volume fraction loss is then calculated by dividing the volume of the separated/evaporated material by the volume of the starting sample and multiplying by 100.

Bibliography

- [1] ISO 10407-1⁶⁾, *Petroleum and natural gas industries — Rotary drilling equipment — Part 1: Drill stem design and operating limits*
- [2] ISO 11007, *Petroleum products and lubricants — Determination of rust-prevention characteristics of lubricating greases*
- [3] ISO 11960 or API SPEC 5CT (*Specification for casing and tubing, 8th Ed.*), *Petroleum and natural gas industries — Steel pipes for use as casing or tubing for wells*
- [4] API BUL 5A2, *Bulletin on thread compounds for casing, tubing, and line pipe*
- [5] API RP 5A3, *Recommended practice on thread compounds for casing, tubing and line pipe*
- [6] API RP 7A1,¹⁾ *Testing of thread compound for rotary shouldered connections*
- [7] API 1997, *API Thread compound research, Full-scale performance tests of environmentally acceptable thread compounds* (summary report)
- [8] API PRAC Project 88-51, 89-51, 91-51:1992, *Investigation of pipe thread compounds*
- [9] ASME B1.1, *Unified Inch Screw Threads, UN and UNR Thread Form*
- [10] ASTM B117, *Standard Practice for Operating Salt Spray (Fog) Apparatus*
- [11] ASTM C561, *Standard Test Method for Ash in a Graphite Sample*
- [12] ASTM D128, *Standard Test Methods for Analysis of Lubricating Grease*
- [13] ASTM D283, *Standard Test Methods for Chemical Analysis of Cuprous Oxide and Copper Pigments*
- [14] ASTM D445, *Standard Test Method for Kinematic Viscosity of Transparent and Opaque Liquids (and Calculation of Dynamic Viscosity)*
- [15] ASTM D521, *Standard Test Methods for Chemical Analysis of Zinc Dust (Metallic Zinc Powder)*
- [16] ASTM D566, *Standard Test Method for Dropping Point of Lubricating Grease*
- [17] ASTM D1301, *Standard Test Methods for Chemical Analysis of White Lead Pigments*
- [18] ASTM D1743, *Standard Test Method for Determining Corrosion Preventive Properties of Lubricating Greases*
- [19] ASTM D2196, *Standard Test Methods for Rheological Properties of Non-Newtonian Materials by Rotational (Brookfield type) Viscometer*
- [20] ASTM D2265, *Standard Test Method for Dropping Point of Lubricating Grease Over Wide Temperature Range*
- [21] ASTM D2509, *Standard Test Method for Measurement of Load-Carrying Capacity of Lubricating Grease (Timken Method)*
- [22] ASTM D2596, *Standard Test Method for Measurement of Extreme-Pressure Properties of Lubricating Grease (Four-Ball Method)*

6) Under preparation. (Revision of ISO 10407:1993)

- [23] ASTM E11, *Standard Specification for Wire Cloth and Sieves for Testing Purposes*
- [24] ASTM E478, *Standard Test Methods for Chemical Analysis of Copper Alloys*
- [25] DIN 51802, *Testing Lubricating Greases for their Corrosion-Inhibiting Properties by the SKF Emcor Method*
- [26] NACE 134, *Evaluation of the Corrosion Inhibition Property of Storage Compounds*, CHOI, H.J. and JONES, S.B.
- [27] NF X 41-002, *Protection contre les agents physiques chimiques et biologiques — Essai au brouillard salin (Protection against physical, chemical and biological agents — Salt spray test)*
- [28] SPE 11396, *A Test Program for the Evaluation of Oilfield Thread Protectors*, DALE, B.A., MOYER, M.C. and SAMPSON, T.W., 1983
- [29] Federal Test Method Standard 791B-321.2, *Oil separation test for grease*

ICS 75.180.10

Price based on 47 pages